

Genesis®

Quick Release Nose Equipment

QUICK RELEASE NOSE ASSEMBLIES:

71210-20310 - Assembly incorporating 71210-15001 Jaw (for G2 tool types)

71220-20310 - Assembly incorporating 71210-15001 Jaw (for G3/4 tool types)

71220-20350 - Assembly incorporating 71610-02002 Jaw (for G3/4 tool types)

Note: Refer to tool Instruction Manual 'Nose Equipment' for Jaw type and appropriate Nose Tip for specified fastener.

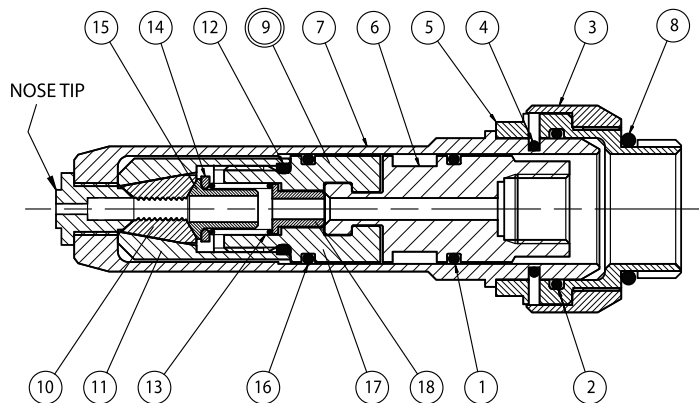
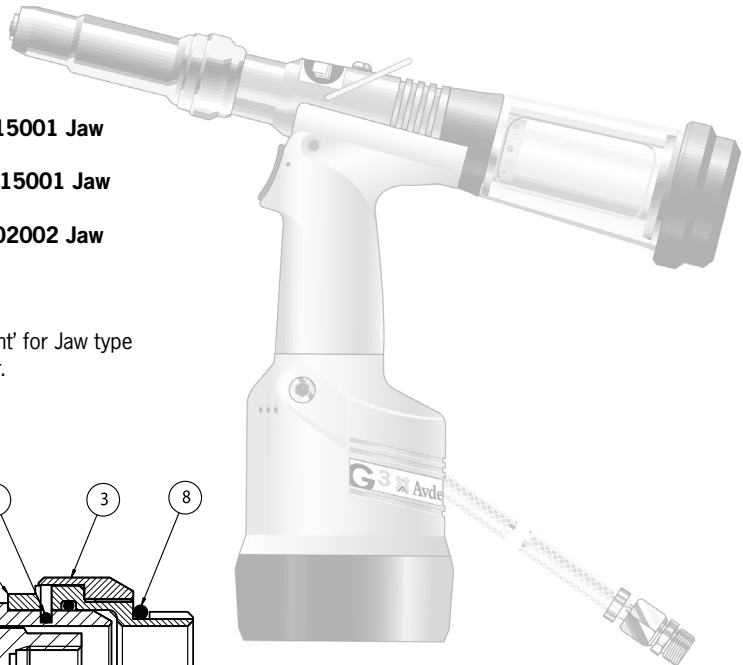

		GENESIS® TOOL TYPE		
		nG1/nG2/nG2s G2/G2s/G2HD	nG3/nG4 G3/G4/G3HD/G4HD	nG3/nG4 G3/G4/G3HD/G4HD
ITEM	DESCRIPTION			
	QUICK RELEASE NOSE ASSEMBLY	71210-20310	71220-20310	71220-20350
1	'O' Ring	07003-00277	07003-00369	07003-00369
2	'O' Ring	07003-00342	07003-00368	07003-00368
3	Spring Cover	71210-20311	71220-20311	71220-20311
4	'U' Spring	71210-20312	71220-20312	71220-20312
5	Nose Case Adaptor	71210-20313	71220-20313	71220-20313
6	'T' Adaptor	71210-20314	71220-20314	71220-20314
7	Quick Release Nose Casing	71210-20316	71220-20316	71220-20316
8	'O' Ring	07003-00349	07003-00349	07003-00349
9	*Nose Equipment Cartridge	71210-20320	71220-20320	71220-20360
10	Jaw Set	71210-15001	71210-15001	07612-02002
11	Jaw Housing	07340-00304	07340-00304	07612-02003
12	'O' Ring	07003-00349	07003-00349	07003-00349
13	Spring	07500-00418	07500-00418	07500-00418
14	Buffer	71210-05001	07498-03003	07498-03003
15	Jaw Spreader	07498-04502	07498-04502	07498-04502
16	'O' Ring	07003-00277	71220-20321	71220-20321
18	Detent Sleeve	71210-20322	71220-20322	71220-20322

*Nose Equipment Cartridge comprising Items 10 to 18

Genesis® Quick Release Nose Equipment

To Prepare Base Tool to Accept Quick Release Nose Equipment

(Refer to the relevant Genesis® Tool Instruction Manual.)

- For nG3/4, G3/4 and G2/G2s tools remove Jaw Spreader Housing 71210-02101.
- For nG1, nG2 and nG2s tools remove 'T' Adaptor 71213-02020.
- Replace above part with 'T' Adaptor (item **6**). **Note:** For nG3/4 tools 'T' Adaptor (item **6**) is assembled through Nose Case Adaptor Assembly (items **2, 3, 4, 5** and **8**).
- Screw the Nose Case Adaptor Assembly (items **2, 3, 4, 5** and **8**) into the front of the tool.
- The Nose Equipment Cartridge (item **9**) is assembled onto the 'T' Adaptor (item **6**) by sliding in a plane normal to the Piston.
- Push the Quick Release Nose Casing (item **7**) into the Nose Case Adaptor (item **5**) ensuring flats are aligned, this locks the Quick Release Nose Casing into position.

To Remove the Quick Release Nose Equipment

- Rotate the Quick Release Nose Casing (item **7**) through 90 degrees and pull out of the Nose Case Adaptor (item **5**).
- To release the Nose Equipment Cartridge (item **9**) from 'T' Adaptor (item **6**) slide cartridge in a plane normal to the head Piston.

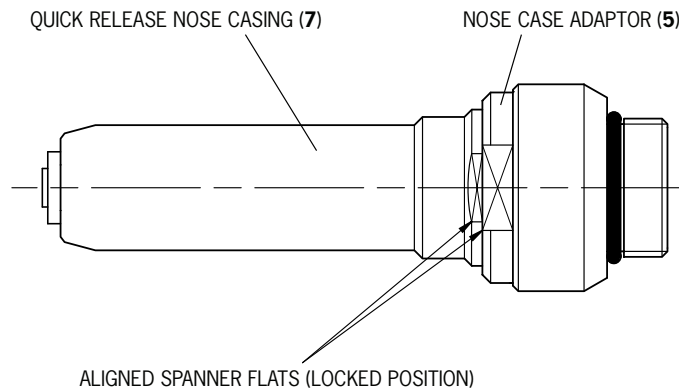

Date Sheet No	Issue	Change Note No.
07900-00798	B	08/198

Item numbers in **bold** refer to the Parts List on the front page.

Avdel UK Limited

Watchmead Industrial Estate, Welwyn Garden City, Herts, AL7 1LY United Kingdom

Tel: +44 1707 292000

Facsimile: +44 1707 292199

www.avdel-global.com