

Putting into Service

Mechanical Cursors

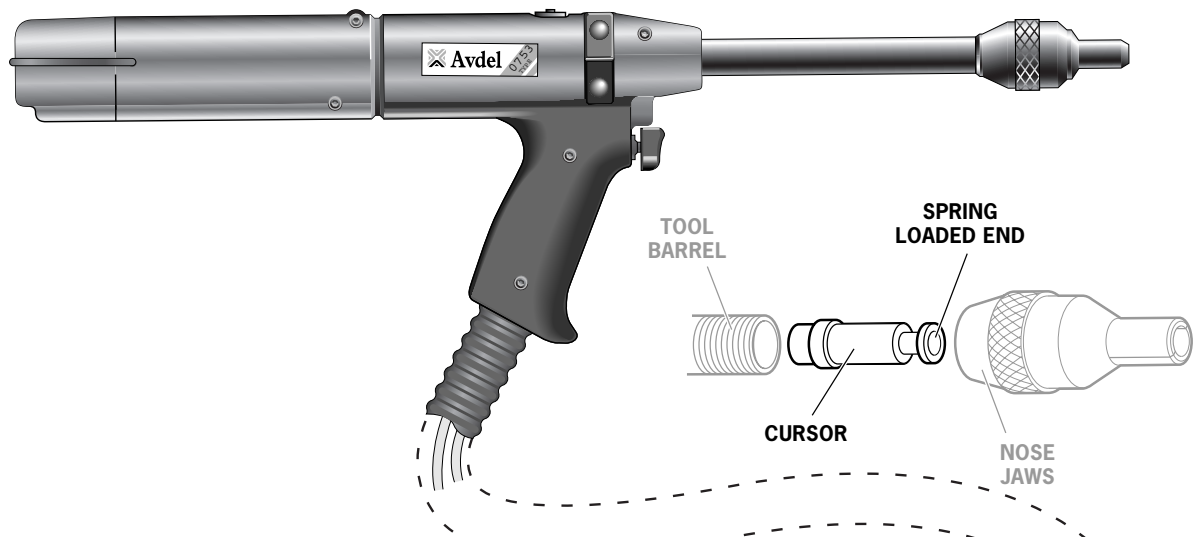

For reference there are three different mechanical cursor types:

- 07271-01100 Used for Standard mandrels and 5/32" Disposable mandrels
- 07279-05843 Used for 1/8" Disposable mandrels
- 07279-05845 Used for 3/16" Disposable mandrels

The difference in the above assemblies is the internal diameter of the End Plug.

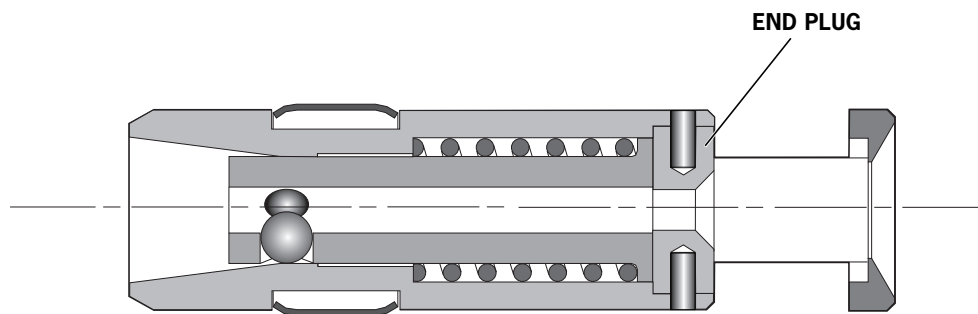

These are colour coded see below:

MECHANICAL CURSOR PART NO.	END PLUG PART NO.	COLOUR	HOLE DIAMETER (mm)
07271-01100	07150-00402	PLAIN STEEL	2.7
07279-05843	07159-05844	GOLD	2.2
07279-05845	07159-05846	SILVER	3.3

Putting into Service

MANDREL FOLLOWER SPRINGS IDENTIFICATION AND ORIENTATION				
FASTENER		NOSE JAW (SEE NOSE EQUIPMENT SECTION)	MANDREL SIZE	MANDREL/MANDREL FOLLOWER SPRING AND FASTENER ASSEMBLY
NAME	SIZE			
BRIV®	3/32"	STANDARD TAPERED	ALL	
	3/32"	LIMITED ACCESS & LIMITED ACCESS CAM OPERATED	ALL	
	1/8"	ALL	ALL	
	5/32"	ALL	ALL	
	3/16"	ALL	ALL	
	6mm	STANDARD	ALL EXCEPT 3rd OVERSIZE	
CHOBERT® AVLUG® GROVIT®	3/32"	ALL EXCEPT STANDARD TAPERED, LIMITED ACCESS	ALL	
	3/32"	STANDARD TAPERED, LIMITED ACCESS	ALL	
	1/8"	ALL	ALL	
CHOBERT® GROVIT®	5/32"	ALL	ALL EXCEPT 3rd OVERSIZE	
	5/32"	ALL	3rd OVERSIZE	
	3/16"	ALL	ALL EXCEPT 2nd OVERSIZE	
	3/16"	ALL	2nd OVERSIZE	
CHOBERT®	1/4"	ALL	ALL	
RIVSCREW®	2.8mm	ALL	ALL	
	3mm			
	3.5mm			
	4mm			
AVSERT®	2.5mm	ALL	ALL	
	4 x 40 UNC	ALL	ALL	
	3mm			
6 x 32 UNC	ALL	ALL		
AVTRONIC®	2.5mm	ALL	ALL	
	2.8mm	ALL EXCEPT LIMITED ACCESS	ALL	
	2.8mm	LIMITED ACCESS	ALL	

Nose Assemblies

On speed fastening tools such as 0753 MkII type, the nose equipment always consists of three elements: a nose jaw, a mandrel and a mandrel follower spring. All three items are matched to the fastener being placed and to the hole size in the application.

IMPORTANT

To avoid complete dismantling of the tool it is essential to check the orientation of the cursor before fitting the nose equipment to the tool. See 'CURSOR' section on page 10.

It is essential that the correct nose equipment is fitted to the tool to ensure both effective placing of the fastener and SAFE operation of the tool. READ THE SAFETY INSTRUCTIONS page 4 carefully.

To identify the correct combination of nose equipment to fit your tool first select a nose jaw by reading the section below then read the mandrel section to select part numbers both for the mandrel itself and for the mandrel follower spring. Mandrels and mandrel follower springs are illustrated on page 12.

To fit the nose equipment, follow the 'Loading the Tool' procedure page 11.

Nose Jaws

IMPORTANT

The wrong nose jaw could result in an incorrectly placed fastener or incorrect clench.

Nose Jaws can be categorised into 7 different basic shapes as illustrated opposite, even though internal dimensions will vary according to the fastener it is intended for. Exact dimensions referring to the letters in the illustrations opposite are indicated in the 'Nose Jaw Selection Tables' on pages 15-16.

For a particular shape, there may be several options of end form giving access benefits or fastener placing enhancement.

Flat

- Normal end form of all nose jaws.
- Suitable on all applications with no access restrictions.

Universal

- Designed for use with universal head Chobert® fasteners.
- Can also be used with Briv® fasteners to obtain the highest possible clench. Note this reduces the maximum grip range of the Briv® fastener by approximately 0.015" (0.4mm).

Recessed

- For use with Briv® fasteners ONLY.
- It gives a higher clench than a flat end form but less than a universal end form, with no reduction of the grip range of the fastener.

Tapered

- Available as shown in the 'Nose Jaw Selection Tables'.
- Allows greater accessibility than a flat end form and places the same range.

Head Forming

- For use with Rivscrew® fasteners ONLY.
- Deforms the head of the fastener to achieve good clench.

Nose Assemblies

Selecting a Nose Jaw

- List the name, size and material of the fastener to be placed.
- Look for this fastener in the first column of the nose jaw selection tables on page 15 if you use imperial measurements and on page 16 if you use metric units.
- Looking right across the table, take note of which nose jaws are available. ONLY those shown are available.
- Select which is most suitable for your application by referring to the respective nose jaw drawing. If your application has no access restriction, you should select the standard shape with a flat end form with or without a cam.

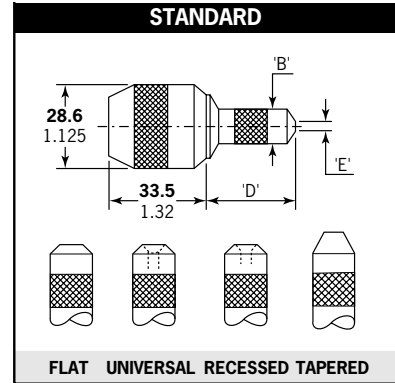

Available in 4 different end forms to place all fasteners (except Rivscrew). Suitable on applications with no or little access restriction.

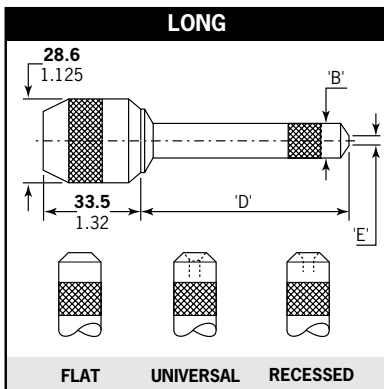

Available to place most of the fasteners. Allows more penetration into applications with no other access restriction.

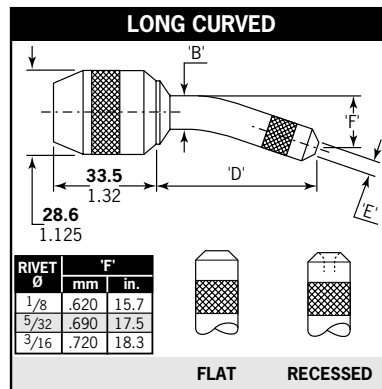

Available as shown in NOSE JAW SELECTION TABLE. Allows more penetration into applications with restricted access. Mandrels must be curved by hand to follow the shape of the jaw.

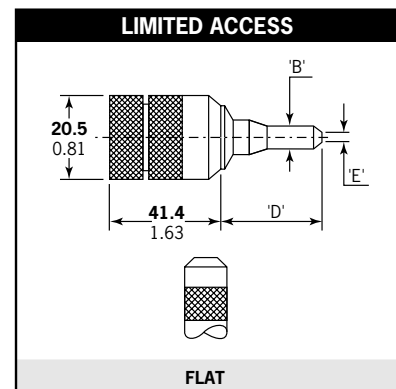

Available as shown in NOSE JAW SELECTION TABLE. Allows access into very restrictive applications.

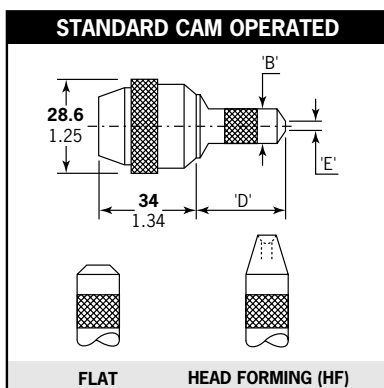

Available as shown in NOSE JAW SELECTION TABLE overleaf. Equivalent functions to the Standard and Limited Access above with the addition of a cam to ease and speed up the nose jaw opening thus the pod reloading procedure.

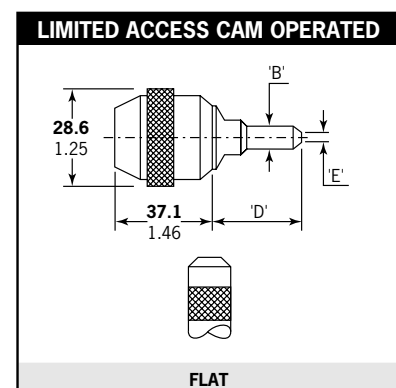
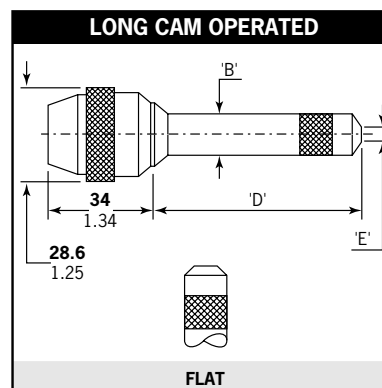

Dimensions shown in **bold** are millimetres. Other dimensions are in inches.

Nose Assemblies

Nose Jaw Selection - Imperial

The 'REF N°' column cross references with the 'REF N°' columns in the mandrel section. It identifies both the mandrel and mandrel follower spring required for a particular nose jaw with a specific fastener.

FASTENER	REF. N°	NOSE JAW					REF. N°	NOSE JAW				
		TYPE AND END FORM	PART N°	DIMENSIONS				TYPE AND END FORM	PART N°	DIMENSIONS		
				'B'	'D'	'E'				'B'	'D'	'E'
3/32" CHOBERT® & GROVIT	1	STANDARD - FLAT	07150-03003	.36	1.30	.16	1	# STANDARD - UNIVERSAL	07150-03203	.36	1.33	.24
	1	STD. CAM OPERATED - FLAT	07170-04500	.36	1.30	.16	1	LTD. ACCESS CAM OPERATED	07177-03003	.20	1.18	.16
	2	STANDARD - TAPERED	07170-03103	.36	1.30	.16	3	LIMITED ACCESS	07274-01000	.22	1.07	.16
	4	LONG - FLAT	07150-04003	.41	2.30	.16	4	LONG CURVED - FLAT	07150-05003	.41	2.28	.16
1/8" CHOBERT® & GROVIT	5	STANDARD - FLAT	07150-03004	.41	1.18	.20	5	# STANDARD - UNIVERSAL	07150-03204	.41	1.22	.32
	5	STANDARD - TAPERED	07170-03104	.41	1.19	.20	5	STD. CAM OPERATED - FLAT	07170-04600	.41	1.18	.20
	6	LONG - FLAT	07150-04004	.41	2.18	.20	6	# LONG - UNIVERSAL	07150-04204	.41	2.22	.30
	6	LONG CURVED - FLAT	07150-05004	.41	2.12	.20	6	LONG CAM OPERATED - FLAT	07170-05000	.41	2.18	.20
5/32" CHOBERT® & GROVIT	7	STANDARD - FLAT	07150-03005	.48	1.30	.24	7	# STANDARD - UNIVERSAL	07150-03205	.48	1.35	.41
	7	STANDARD - TAPERED	07150-03105	.44	1.30	.24	7	STD. CAM OPERATED - FLAT	07170-04700	.48	1.30	.24
	8	LONG - FLAT	07150-04005	.48	2.30	.24	8	# LONG - UNIVERSAL	07150-04205	.48	2.35	.42
	8	LONG CURVED - FLAT	07150-05005	.48	2.23	.24	8	LONG CAM OPERATED - FLAT	07170-05100	.48	2.30	.24
3/16" CHOBERT® & GROVIT	9	STANDARD - FLAT	07150-03006	.56	1.18	.33	9	# STANDARD - UNIVERSAL	07150-03206	.56	1.24	.47
	9	STANDARD - TAPERED	07150-03106	.56	1.18	.33	9	STD. CAM OPERATED - FLAT	07170-04800	.56	1.18	.33
	10	LONG - FLAT	07150-04006	.56	2.30	.33	10	# LONG - UNIVERSAL	07150-04206	.56	2.39	.48
	10	LONG CURVED - FLAT	07150-05006	.56	2.21	.33	10	LONG CAM OPERATED - FLAT	07170-05200	.56	2.30	.33
1/4" CHOBERT®	11	STANDARD - FLAT	07150-03008	.64	1.18	.39	11	STD. CAM OPERATED - FLAT	07170-04900	.64	1.18	.39
	12	LONG - FLAT	07150-04008	.64	2.18	.39	12	LONG CAM OPERATED - FLAT	07170-05300	.64	2.18	.39
3/32" BRIV® Brass only	13	STANDARD - TAPERED	07170-03103	.36	1.30	.15	14	LTD. ACCESS CAM OPERATED	07177-03003	.20	1.18	.16
	14	LIMITED ACCESS	07274-01000	.22	1.07	.16	-	-	-	-	-	-
1/8" BRIV® Al. Alloy, Brass, Steel	15	STANDARD - FLAT	07150-03004	.41	1.18	.20	15	STANDARD - RECESSED	07170-03004	.41	1.20	.30
	15	STANDARD - TAPERED	07170-03104	.41	1.19	.20	16	LONG - FLAT	07150-04004	.41	2.18	.20
	16	LONG - RECESSED	07170-03204	.41	2.18	.30	16	LONG CURVED - FLAT	07150-05004	.41	2.12	.20
	16	LONG CURVED - RECESSED	07170-03304	.41	2.12	.30	-	-	-	-	-	-
5/32" BRIV® Al. Alloy, Brass, Steel	17	STANDARD - FLAT	07150-03005	.48	1.30	.24	17	STANDARD - RECESSED	07170-03005	.48	1.32	.41
	18	LONG - FLAT	07150-04005	.48	2.30	.24	18	LONG - RECESSED	07170-03205	.48	2.30	.41
	18	LONG CURVED - FLAT	07150-05005	.48	2.23	.24	18	LONG CURVED - RECESSED	07170-03305	.48	2.23	.41
5/32" BRIV® St. Steel only	19	STANDARD - FLAT	07150-03005	.48	1.30	.24	19	STANDARD - RECESSED	07170-03005	.48	1.32	.41
	20	LONG - FLAT	07150-04005	.48	2.30	.24	20	LONG - RECESSED	07170-03205	.48	2.30	.41
	20	LONG CURVED - FLAT	07150-05005	.48	2.23	.24	20	LONG CURVED - RECESSED	07170-03305	.48	2.23	.41
3/16" BRIV® Al. Alloy, Brass, Steel	21	STANDARD - FLAT	07150-03006	.56	1.18	.33	21	STANDARD - RECESSED	07170-03006	.56	1.20	.47
	22	LONG - FLAT	07150-04006	.56	2.30	.33	22	LONG - RECESSED	07170-03206	.56	2.30	.47
	22	LONG CURVED - FLAT	07150-05006	.56	2.21	.33	22	LONG CURVED - RECESSED	07170-03306	.56	2.21	.47
3/16" BRIV® St. Steel only	23	STANDARD - FLAT	07150-03006	.56	1.18	.33	23	STANDARD - RECESSED	07170-03006	.56	1.20	.47
	24	LONG - FLAT	07150-04006	.56	2.30	.33	24	LONG - RECESSED	07170-03206	.56	2.30	.47
	24	LONG CURVED - FLAT	07150-05006	.56	2.21	.33	24	LONG CURVED - RECESSED	07170-03306	.56	2.21	.47
6mm BRIV® Al. Alloy, Steel	25	STD. CAM OPERATED	07170-05600	.64	1.21	.52	25	STANDARD - FLAT	07170-05800	.64	1.21	.52
	26	LONG CAM OPERATED	07170-05700	.64	2.19	.52	26	LONG - FLAT	07170-05900	.64	2.19	.52
3/32" AVLUG®	27	STANDARD - FLAT	07150-03003	.36	1.30	.16	27	STANDARD - TAPERED	07150-03103	.36	1.30	.16
	27	STD. CAM OPERATED - FLAT	07170-04500	.36	1.30	.16	28	LONG - FLAT	07150-04003	.41	2.30	.16
	28	LONG CURVED - FLAT	07150-05003	.41	2.28	.16	-	-	-	-	-	-
1/8" AVLUG®	29	STANDARD - FLAT	07150-03004	.41	1.18	.20	29	STANDARD - TAPERED	07170-03104	.41	1.19	.20
	29	STD. CAM OPERATED - FLAT	07170-04600	.41	1.18	.20	30	LONG - FLAT	07150-04004	.41	2.18	.20
	30	LONG CURVED - FLAT	07150-05004	.41	2.12	.20	30	LONG CAM OPERATED - FLAT	07170-05000	.41	2.18	.20
2.5mm, 4-40 UNC AVSERT®	31	STANDARD - FLAT	07150-03003	.36	1.30	.16	-	-	-	-	-	-
3.0mm, 6-32 UNC AVSERT®	32	STANDARD - FLAT	07150-03004	.41	1.18	.20	32	STD. CAM OPERATED - FLAT	07170-04600	.41	1.18	.20
2.5mm AVTRONIC®	33	STANDARD - FLAT	07150-03003	.36	1.30	.16	33	LTD. ACCESS CAM OPERATED	07271-08000	.41	1.18	.16
	34	LONG - FLAT	07150-04003	.41	2.30	.16	-	-	-	-	-	-
2.8mm AVTRONIC®	35	STANDARD - FLAT	07271-05600	.36	1.30	.16	36	LTD. ACCESS CAM OPERATED	07271-08100	.40	1.18	.16
	37	LONG - FLAT	07271-05900	.41	2.30	.16	-	-	-	-	-	-
2.8mm RIVSCREW®	38	STD. CAM OPERATED - HF	07271-03000	.41	1.18	.24	-	-	-	-	-	-
3.0mm RIVSCREW®	39	STD. CAM OPERATED - HF	07271-03000	.41	1.18	.24	-	-	-	-	-	-
3.5mm RIVSCREW®	40	STD. CAM OPERATED - HF	07271-03500	.41	1.18	.24	-	-	-	-	-	-
4.0mm RIVSCREW®	41	STD. CAM OPERATED - HF	07271-04000	.41	1.18	.25	-	-	-	-	-	-

These nose jaws are suitable for placing Chobert® rivets with a Universal Head Form. When used on the equivalent size of Briv®, the highest possible clench is achieved. Note when using Briv® fasteners, the maximum grip is reduced by approximately 0.015" (0.4mm). possible clench is achieved. Note that when using Briv fasteners, the maximum grip is reduced by approximately 0.015" (0.4 mm).

Nose Assemblies

Nose Jaw Selection - Metric

FASTENER	REF. N°	NOSE JAW					REF. N°	NOSE JAW				
		TYPE AND END FORM	PART N°	DIMENSIONS				TYPE AND END FORM	PART N°	DIMENSIONS		
				'B'	'D'	'E'				'B'	'D'	'E'
3/32" CHOBERT® & GROVIT	1	STANDARD - FLAT	07150-03003	9.14	33.02	4.06	1	# STANDARD - UNIVERSAL	07150-03203	9.14	33.78	6.10
	1	STD. CAM OPERATED - FLAT	07170-04500	9.14	33.02	4.06	1	LTD. ACCESS CAM OPERATED	07177-03003	5.08	29.97	4.06
	2	STANDARD - TAPERED	07170-03103	9.14	33.02	4.06	3	LIMITED ACCESS	07274-01000	5.59	27.18	4.06
	4	LONG - FLAT	07150-04003	10.41	58.42	4.06	4	LONG CURVED - FLAT	07150-05003	10.41	57.91	4.06
1/8" CHOBERT® & GROVIT	5	STANDARD - FLAT	07150-03004	10.41	29.97	5.08	5	# STANDARD - UNIVERSAL	07150-03204	10.41	30.99	8.13
	5	STANDARD - TAPERED	07170-03104	10.41	30.23	5.08	5	STD. CAM OPERATED - FLAT	07170-04600	10.41	29.97	5.08
	6	LONG - FLAT	07150-04004	10.41	55.37	5.08	6	# LONG - UNIVERSAL	07150-04204	10.41	56.39	7.62
	6	LONG CURVED - FLAT	07150-05004	10.41	53.85	5.08	6	LONG CAM OPERATED - FLAT	07170-05000	10.41	55.37	5.08
5/32" CHOBERT® & GROVIT	7	STANDARD - FLAT	07150-03005	12.19	33.02	6.10	7	# STANDARD - UNIVERSAL	07150-03205	12.19	34.29	10.41
	7	STANDARD - TAPERED	07150-03105	11.18	33.02	6.10	7	STD. CAM OPERATED - FLAT	07170-04700	12.19	33.02	6.10
	8	LONG - FLAT	07150-04005	12.19	58.42	6.10	8	# LONG - UNIVERSAL	07150-04205	12.19	59.69	10.67
	8	LONG CURVED - FLAT	07150-05005	12.19	56.64	6.10	8	LONG CAM OPERATED - FLAT	07170-05100	12.19	58.42	6.10
3/16" CHOBERT® & GROVIT	9	STANDARD - FLAT	07150-03006	14.22	29.97	8.38	9	# STANDARD - UNIVERSAL	07150-03206	14.22	31.50	11.94
	9	STANDARD - TAPERED	07150-03106	14.22	29.97	8.38	9	STD. CAM OPERATED - FLAT	07170-04800	14.22	29.97	8.38
	10	LONG - FLAT	07150-04006	14.22	58.42	8.38	10	# LONG - UNIVERSAL	07150-04206	14.22	60.71	12.19
	10	LONG CURVED - FLAT	07150-05006	14.22	56.13	8.38	10	LONG CAM OPERATED - FLAT	07170-05200	14.22	58.42	8.38
1/4" CHOBERT®	11	STANDARD - FLAT	07150-03008	16.26	29.97	9.91	11	STD. CAM OPERATED - FLAT	07170-04900	16.26	29.97	9.91
	12	LONG - FLAT	07150-04008	16.26	55.37	9.91	12	LONG CAM OPERATED - FLAT	07170-05300	16.26	55.37	9.91
3/32" BRIV® Brass only	13	STANDARD - TAPERED	07170-03103	9.14	33.02	3.81	14	LTD. ACCESS CAM OPERATED	07177-03003	5.08	29.97	4.06
	14	LIMITED ACCESS	07274-01000	5.59	27.18	4.06	-	-	-	-	-	-
1/8" BRIV® Al. Alloy, Brass, Steel	15	STANDARD - FLAT	07150-03004	10.41	29.97	5.08	15	STANDARD - RECESSED	07170-03004	10.41	30.48	7.62
	15	STANDARD - TAPERED	07170-03104	10.41	30.23	5.08	16	LONG - FLAT	07150-04004	10.41	55.37	5.08
	16	LONG - RECESSED	07170-03204	10.41	55.37	7.62	16	LONG CURVED - FLAT	07150-05004	10.41	53.85	5.08
	16	LONG CURVED - RECESSED	07170-03304	10.41	53.85	7.62	-	-	-	-	-	-
5/32" BRIV® Al. Alloy, Brass, Steel	17	STANDARD - FLAT	07150-03005	12.19	33.02	6.10	17	STANDARD - RECESSED	07170-03005	12.19	33.53	10.41
	18	LONG - FLAT	07150-04005	12.19	58.42	6.10	18	LONG - RECESSED	07170-03205	12.19	58.42	10.41
	18	LONG CURVED - FLAT	07150-05005	12.19	56.64	6.10	18	LONG CURVED - RECESSED	07170-03305	12.19	56.64	10.41
5/32" BRIV® St. Steel only	19	STANDARD - FLAT	07150-03005	12.19	33.02	6.10	19	STANDARD - RECESSED	07170-03005	12.19	33.53	10.41
	20	LONG - FLAT	07150-04005	12.19	58.42	6.10	20	LONG - RECESSED	07170-03205	12.19	58.42	10.41
	20	LONG CURVED - FLAT	07150-05005	12.19	56.64	6.10	20	LONG CURVED - RECESSED	07170-03305	12.19	56.64	10.41
3/16" BRIV® Al. Alloy, Brass, Steel	21	STANDARD - FLAT	07150-03006	14.22	29.97	8.38	21	STANDARD - RECESSED	07170-03006	14.22	30.48	11.94
	22	LONG - FLAT	07150-04006	14.22	58.42	8.38	22	LONG - RECESSED	07170-03206	14.22	58.42	11.94
	22	LONG CURVED - FLAT	07150-05006	14.22	56.13	8.38	22	LONG CURVED - RECESSED	07170-03306	14.22	56.13	11.94
3/16" BRIV® St. Steel only	23	STANDARD - FLAT	07150-03006	14.22	29.97	8.38	23	STANDARD - RECESSED	07170-03006	14.22	30.48	11.94
	24	LONG - FLAT	07150-04006	14.22	58.42	8.38	24	LONG - RECESSED	07170-03206	14.22	58.42	11.94
	24	LONG CURVED - FLAT	07150-05006	14.22	56.13	8.38	24	LONG CURVED - RECESSED	07170-03306	14.22	56.13	11.94
6mm BRIV® Al. Alloy, Steel	25	STD. CAM OPERATED	07170-05600	16.33	30.65	13.14	25	STANDARD - FLAT	07170-05800	16.33	30.65	13.14
	26	LONG CAM OPERATED	07170-05700	16.33	55.65	13.14	26	LONG - FLAT	07170-05900	16.33	55.65	13.14
	27	STANDARD - FLAT	07150-03003	9.14	33.02	4.06	27	STANDARD - TAPERED	07150-03103	9.14	33.02	4.06
3/32" AVLUG®	27	STD. CAM OPERATED - FLAT	07170-04500	9.14	33.02	4.06	28	LONG - FLAT	07150-04003	10.41	58.42	4.06
	28	LONG CURVED - FLAT	07150-05003	10.41	57.91	4.06	-	-	-	-	-	-
	29	STANDARD - FLAT	07150-03004	10.41	29.97	5.08	29	STANDARD - TAPERED	07170-03104	10.41	30.23	5.08
1/8" AVLUG®	29	STD. CAM OPERATED - FLAT	07170-04600	10.41	29.97	5.08	30	LONG - FLAT	07150-04004	10.41	55.37	5.08
	30	LONG CURVED - FLAT	07150-05004	10.41	53.85	5.08	30	LONG CAM OPERATED - FLAT	07170-05000	10.41	55.37	5.08
	31	STANDARD - FLAT	07150-03003	9.14	33.02	4.06	-	-	-	-	-	-
2.5mm, 4-40 UNC AVSERT®	32	STANDARD - FLAT	07150-03004	10.41	29.97	5.08	32	STD. CAM OPERATED - FLAT	07170-04600	10.41	29.97	5.08
3.0mm, 6-32 UNC AVSERT®	33	STANDARD - FLAT	07150-03003	9.14	33.02	4.06	33	LTD. ACCESS CAM OPERATED	07271-08000	10.41	29.97	4.06
2.5mm AVTRONIC®	34	LONG - FLAT	07150-04003	10.41	58.42	4.06	-	-	-	-	-	-
	35	STANDARD - FLAT	07271-05600	9.14	33.02	4.06	36	LTD. ACCESS CAM OPERATED	07271-08100	10.16	29.97	4.06
2.8mm AVTRONIC®	37	LONG - FLAT	07271-05900	10.41	58.42	4.06	-	-	-	-	-	-
	38	STD. CAM OPERATED - HF	07271-03000	10.41	29.97	6.10	-	-	-	-	-	-
3.0mm RIVSCREW®	39	STD. CAM OPERATED - HF	07271-03000	10.41	29.97	6.10	-	-	-	-	-	-
3.5mm RIVSCREW®	40	STD. CAM OPERATED - HF	07271-03500	10.41	29.97	6.10	-	-	-	-	-	-
4.0mm RIVSCREW®	41	STD. CAM OPERATED - HF	07271-04000	10.41	29.97	6.35	-	-	-	-	-	-

These nose jaws are suitable for placing Chobert® rivets with a Universal Head Form. When used on the equivalent size of Briv®, the highest possible clench is achieved. Note that when using Briv® fasteners, the maximum grip is reduced by approximately 0.015" (0.4mm). possible clench is achieved. Note that when using Briv fasteners, the maximum grip is reduced by approximately 0.015" (0.4 mm).

Nose Assemblies

Mandrels and Mandrel Follower Springs

Mandrels and mandrel follower springs, illustrated on page 12 need to be selected to suit the fastener type and size as well as the size of the hole in the application. Use of the wrong mandrel could increase the risk of breakage and the wear of the mandrel head. Feeding problems could occur if the wrong mandrel follower spring is used.

IMPORTANT

READ THE SAFETY INSTRUCTIONS page 4 carefully.

While a small amount of wear and marking will naturally occur through normal and correct use of mandrels, they must be regularly examined for excessive wear and marking, with particular attention to the head diameter, the tail jaw gripping area of the shank or heavy pitting of the shank and any mandrel distortion. Mandrels which fail during use could forcibly exit the tool. It is the customer's responsibility to ensure that mandrels are replaced before any excessive levels of wear and always before the maximum recommended number of placings. Contact your Avdel representative who will let you know what that figure is by measuring the broach load of your application with our calibrated measuring tool. These tools can also be purchased under part number 07900-09080, supplied with all necessary information for testing.

Chobert® and Grovit® - Imperial

For mandrel or mandrel follower spring selection, follow instructions on page 19.

FASTENER	REF. N°	HOLE SIZE	STANDARD MANDREL - GREEN					HOLE SIZE	1ST OVERSIZE MANDREL - YELLOW					SPRING PART N°
			HEAD Ø	MANDREL PART N°	P MAX.	# S/R MANDREL PART N°	P MAX.		HEAD Ø	MANDREL PART N°	P MAX.	# S/R MANDREL PART N°	P MAX.	
3/32" CHOBERT® & GROVIT®	1	AS REC.	.0725	07150-06003	.166	07150-08003	.071	+0.015	.074	07150-06303	.174	-	-	07150-06803
	1	-	-	-	-	-	-	+0.035	.076	-	-	07150-08103	.078	07150-06803
	2	AS REC.	.0725	07150-06003	.166	07150-08003	.071	+0.015	.074	07150-06303	.174	-	-	07170-06873
	2	-	-	-	-	-	-	+0.035	.076	-	-	07150-08103	.078	07170-06873
	3	AS REC.	.0725	07150-06003	.166	07150-08003	.071	+0.015	.074	07150-06303	.174	-	-	07170-06903
	3	-	-	-	-	-	-	+0.035	.076	-	-	07150-08103	.078	07170-06903
1/8" CHOBERT® & GROVIT®	4	AS REC.	.0725	07150-07003	.166	07150-09003	.071	+0.035	.076	-	-	07150-09103	.078	07150-07803
	5	AS REC.	.088	07150-06004	.216	07150-08004	.090	+0.04	.092	07150-06104	.237	07150-08104	.098	07150-06804
5/32" CHOBERT® & GROVIT®	6	AS REC.	.088	07150-07004	.216	07150-09004	.090	+0.04	.092	07150-07104	.237	07150-09104	.098	07150-07804
	7	AS REC.	.107	07150-06005	.244	07150-08005	.100	+0.08	.115	07150-06105	.284	07150-08105	.116	07170-06875
	7	-	-	-	-	-	-	-	-	-	-	-	-	-
	8	AS REC.	.107	07150-07005	.244	07150-09005	.100	+0.08	.115	07150-07105	.284	07150-09105	.116	07170-07875
3/16" CHOBERT® & GROVIT®	8	-	-	-	-	-	-	-	-	-	-	-	-	-
	9	AS REC.	.132	07150-06006	.247	07150-08006	.102	+0.14	.146	07150-06106	.320	07150-08106	.130	07170-06876
	9	-	-	-	-	-	-	-	-	-	-	-	-	-
	10	AS REC.	.132	07150-07006	.247	07150-09006	.102	+0.14	.146	07150-07106	.320	07150-09106	.130	07170-07876
1/4" CHOBERT®	10	-	-	-	-	-	-	-	-	-	-	-	-	-
	11	AS REC.	.184	07150-06008	.268	07150-08008	.110	+0.12	.196	07150-06108	.330	07150-08108	.134	07150-06808
	12	AS REC.	.184	07150-07008	.268	07150-09008	.110	+0.12	.196	07150-07108	.330	07150-09108	.134	07150-07808

FASTENER	REF. N°	HOLE SIZE	2ND OVERSIZE MANDREL - BLUE					HOLE SIZE	3RD OVERSIZE MANDREL - RED					SPRING PART N°
			HEAD Ø	MANDREL PART N°	P MAX.	# S/R MANDREL PART N°	P MAX.		HEAD Ø	MANDREL PART N°	P MAX.	# S/R MANDREL PART N°	P MAX.	
3/32" CHOBERT® & GROVIT®	1	+0.035	.076	07150-06103	.185	-	-	-	-	-	-	-	-	07150-06803
	1	-	-	-	-	-	-	-	-	-	-	-	-	-
	2	+0.035	.076	07150-06103	.185	-	-	-	-	-	-	-	-	07170-06873
	2	-	-	-	-	-	-	-	-	-	-	-	-	-
	3	+0.035	.076	07150-06103	.185	-	-	-	-	-	-	-	-	07170-06903
	3	-	-	-	-	-	-	-	-	-	-	-	-	-
1/8" CHOBERT® & GROVIT®	4	+0.035	.076	07150-07103	.185	-	-	-	-	-	-	-	-	07150-07803
	5	+0.10	.098	07150-06204	.268	07150-08204	.110	+0.14	.102	07150-06304	.288	07150-08304	.118	07150-06804
5/32" CHOBERT® & GROVIT®	6	+0.10	.098	07150-07204	.268	07150-09204	.110	+0.14	.102	07150-07304	.288	07150-09304	.118	07150-07804
	7	+0.15	.122	07150-06205	.320	07150-08205	.130	-	-	-	-	-	-	07170-06875
	7	-	-	-	-	-	-	+0.025	.132	07150-06305	.372	07150-08305	.150	07150-06805
	8	+0.15	.122	07150-07205	.320	07150-09205	.130	-	-	-	-	-	-	07170-07875
3/16" CHOBERT® & GROVIT®	8	-	-	-	-	-	-	+0.025	.132	07150-07305	.372	07150-09305	.150	07150-07805
	9	-	-	-	-	-	-	-	-	-	-	-	-	-
	9	+0.24	.156	07150-06206	.372	07150-08206	.150	-	-	-	-	-	-	07150-06806
	10	-	-	-	-	-	-	-	-	-	-	-	-	-
1/4" CHOBERT®	10	+0.24	.156	07150-07206	.372	07150-09206	.150	-	-	-	-	-	-	07150-07806
	11	-	-	-	-	-	-	-	-	-	-	-	-	-
	12	-	-	-	-	-	-	-	-	-	-	-	-	-

S/R: Short Reach Mandrel. See page 19-20 for explanation.

Nose Assemblies

Tables below left and right and over the next four pages list part numbers of all mandrels and mandrel follower springs available per fastener or group of fasteners, i.e. for Chobert® and Grovit® on these pages.

While fastener sizes are always shown in their specified units, each table has been produced twice to offer dimensions in imperial units on the left-hand page then in metric units on the right-hand page. These 'Mandrel Selection' tables cross-reference with the 'Nose Jaw Selection' tables on pages 15-16 through the 'Ref. N°' column.

It is the diameter of the head at the end of a mandrel which when pulled through controls the expansion of the fastener body.

While there are different head shapes to suit different types of fasteners (see illustration on page 20), progressive head sizes are needed to reflect manufacturing tolerances on the diameter of the hole in your application so that the fastener always expands sufficiently to fill the hole.

Too large a mandrel head would overstress the mandrel and mandrels which fail during use could forcibly exit the tool.

Selection tables are arranged into four 'mandrel size' sections, ranging from 'standard' to '3rd oversize', each being colour coded as per the end of the mandrel heads themselves.

Chobert® and Grovit® - Metric

FASTENER	REF. N°	HOLE SIZE	STANDARD MANDREL - GREEN					HOLE SIZE	1ST OVERSIZE MANDREL - YELLOW					SPRING PART N°
			HEAD Ø	MANDREL PART N°	P MAX.	# S/R MANDREL PART N°	P MAX.		HEAD Ø	MANDREL PART N°	P MAX.	# S/R MANDREL PART N°	P MAX.	
3/32" CHOBERT® & GROVIT®	1	AS REC.	1.84	07150-06003	4.22	07150-08003	1.80	+04	1.88	07150-06303	4.42	-	-	07150-06803
	1	-	-	-	-	-	-	+09	1.93	-	-	07150-08103	1.98	07150-06803
	2	AS REC.	1.84	07150-06003	4.22	07150-08003	1.80	+04	1.88	07150-06303	4.42	-	-	07170-06873
	2	-	-	-	-	-	-	+09	1.93	-	-	07150-08103	1.98	07170-06873
	3	AS REC.	1.84	07150-06003	4.22	07150-08003	1.80	+04	1.88	07150-06303	4.42	-	-	07170-06903
	3	-	-	-	-	-	-	+09	1.93	-	-	07150-08103	1.98	07170-06903
	4	AS REC.	1.84	07150-07003	4.22	07150-09003	1.80	+09	1.93	-	-	07150-09103	1.98	07150-07803
	4	-	-	-	-	-	-	-	-	-	-	-	-	-
1/8" CHOBERT® & GROVIT®	5	AS REC.	2.24	07150-06004	5.49	07150-08004	2.29	+10	2.34	07150-06104	6.02	07150-08104	2.49	07150-06804
	6	AS REC.	2.24	07150-07004	5.49	07150-09004	2.29	+10	2.34	07150-07104	6.02	07150-09104	2.49	07150-07804
5/32" CHOBERT® & GROVIT®	7	AS REC.	2.72	07150-06005	6.20	07150-08005	2.54	+20	2.92	07150-06105	7.21	07150-08105	2.95	07170-06875
	7	-	-	-	-	-	-	-	-	-	-	-	-	-
	8	AS REC.	2.72	07150-07005	6.20	07150-09005	2.54	+20	2.92	07150-07105	7.21	07150-09105	2.95	07170-07875
3/16" CHOBERT® & GROVIT®	9	AS REC.	3.35	07150-06006	6.27	07150-08006	2.59	+35	3.71	07150-06106	8.13	07150-08106	3.30	07170-06876
	9	-	-	-	-	-	-	-	-	-	-	-	-	-
	10	AS REC.	3.35	07150-07006	6.27	07150-09006	2.59	+35	3.71	07150-07106	8.13	07150-09106	3.30	07170-07876
1/4" CHOBERT®	11	AS REC.	4.67	07150-06008	6.81	07150-08008	2.79	+30	4.98	07150-06108	8.38	07150-08108	3.40	07150-06808
	12	AS REC.	4.67	07150-07008	6.81	07150-09008	2.79	+30	4.98	07150-07108	8.38	07150-09108	3.40	07150-07808

FASTENER	REF. N°	HOLE SIZE	2ND OVERSIZE MANDREL - BLUE					HOLE SIZE	3RD OVERSIZE MANDREL - RED					SPRING PART N°
			HEAD Ø	MANDREL PART N°	P MAX.	# S/R MANDREL PART N°	P MAX.		HEAD Ø	MANDREL PART N°	P MAX.	# S/R MANDREL PART N°	P MAX.	
3/32" CHOBERT® & GROVIT®	1	+09	1.93	07150-06103	4.70	-	-	-	-	-	-	-	-	07150-06803
	1	-	-	-	-	-	-	-	-	-	-	-	-	-
	2	+09	1.93	07150-06103	4.70	-	-	-	-	-	-	-	-	07170-06873
	2	-	-	-	-	-	-	-	-	-	-	-	-	-
	3	+09	1.93	07150-06103	4.70	-	-	-	-	-	-	-	-	07170-06903
	3	-	-	-	-	-	-	-	-	-	-	-	-	-
1/8" CHOBERT® & GROVIT®	4	+09	1.93	07150-07103	4.70	-	-	-	-	-	-	-	-	07150-07803
	4	-	-	-	-	-	-	-	-	-	-	-	-	-
1/8" CHOBERT® & GROVIT®	5	+25	2.49	07150-06204	6.81	07150-08204	2.79	+35	2.59	07150-06304	7.32	07150-08304	3.00	07150-06804
	6	+25	2.49	07150-07204	6.81	07150-09204	2.79	+35	2.59	07150-07304	7.32	07150-09304	3.00	07150-07804
5/32" CHOBERT® & GROVIT®	7	+38	3.10	07150-06205	8.13	07150-08205	3.30	-	-	-	-	-	-	07170-06875
	7	-	-	-	-	-	-	+63	3.35	07150-06305	9.45	07150-08305	3.81	07150-06805
	8	+38	3.10	07150-07205	8.13	07150-09205	3.30	-	-	-	-	-	-	07170-07875
	8	-	-	-	-	-	-	+63	3.35	07150-07305	9.45	07150-09305	3.81	07150-07805
3/16" CHOBERT® & GROVIT®	9	-	-	-	-	-	-	-	-	-	-	-	-	-
	9	+60	3.96	07150-06206	9.45	07150-08206	3.81	-	-	-	-	-	-	07150-06806
	10	+60	3.96	07150-07206	9.45	07150-09206	3.81	-	-	-	-	-	-	07150-07806
1/4" CHOBERT®	11	-	-	-	-	-	-	-	-	-	-	-	-	-
	12	-	-	-	-	-	-	-	-	-	-	-	-	-

S/R: Short Reach Mandrel. See page 19-20 for explanation.

Nose Assemblies

To find the correct part number of a mandrel for a particular application, read the instructions below after you have gathered the following information as per example alongside. Answers for the example are shown in *grey italic*.

FASTENER NAME	<i>example</i>	<i>Chobert®</i>
FASTENER SIZE		<i>1/8"</i>
DATASHEET		<i>Series 1125</i>
APPLICATION HOLE SIZE		<i>0.1335"</i>
CLEARANCE BEHIND APPLICATION		<i>Infinite</i>
'REF.N°' FROM NOSE JAW SELECTION TABLE		<i>5 (standard flat)</i>

- Subtract the minimum hole size recommended (AS REC.) in the fastener datasheet from the actual application hole size. *-example: 0.005.*
- Turn to the page with the 'Mandrel Selection' table for your fastener, selecting either the imperial or the metric dimensions table (pages 17-21). *-example: page 17.*
- Starting with the 'Standard Mandrel - Green' section, find your fastener size in the left-hand column. *-example 1/8" Chobert® & Grovit®.*
- If you selected a nose jaw which place you fastener, you should now be able to find a line within your fastener section with the same 'Ref No.' as that from the 'Nose Jaw Selection' table. *-example: 5.* This is your line 'Ref. No.' in which you will find both your mandrel and mandrel follower spring part number. This line continues into the second half of the table for the '2nd' and '3rd' oversize mandrels.
- Scan along the line to the 'hole size' columns and select which ever is the nearest or equal to the figure calculated in step one. You may now read the mandrel part number next to the 'hole size'. *-example: 07150-06104*
- For Chobert® and Grovit® only, most mandrels are also available in a 'short reach' version (see illustration on page 20). Short reach mandrels are used to minimise the possibility of the mandrel head contacting a read obstruction. This would result in the underside of the fastener head not seating properly on the application surface, causing a lack on clench in the joint.
- Whichever size mandrel you settle on, you will also need to check the 'P' figure against that mandrel is adequate. 'P' is the clearance required for the mandrel head at the back of the application IN ADDITION to the length of the fastener protruding through the application, as shown in the illustration on page 20.
- You may now read the corresponding mandrel follower spring part number in the right-hand column of the table. *-example: 07150-06804.*

In all cases, satisfactory clenching of the joint should be assessed particularly if the size of the hole in your application is very close to the next oversize hole condition, when it will be safe to select the greater size of mandrel to obtain a higher clench. REMEMBER that this will increase the broach load and reduce the mandrel life.

Briv® - Imperial

For mandrel or mandrel follower spring selection, follow instructions above.

FASTENER	REF. N°	HOLE SIZE	STANDARD MANDREL - GREEN			HOLE SIZE	1ST OVERSIZE MANDREL - YELLOW			SPRING PART N°
			HEAD Ø	MANDREL PART N°	P MAX.		HEAD Ø	MANDREL PART N°	P MAX.	
3/32" BRIV® Brass only	13	AS REC.	.072	07150-06013	.119	+0.04	.076	07150-06113	.123	07170-06873
	14	AS REC.	.072	07150-06013	.119	+0.04	.076	07150-06113	.123	07170-06903
1/8" BRIV® Al. Alloy, Brass, Steel	15	AS REC.	.092	07271-06414	.120	+0.05	.097	07271-06514	.126	07150-06814
	16	AS REC.	.092	07271-07414	.120	+0.05	.097	07271-07514	.126	07150-07814
5/32" BRIV® Al. Alloy, Brass, Steel	17	AS REC.	.110	07150-06015	.136	+0.05	.115	07150-06115	.142	07170-06875
	18	AS REC.	.110	07150-07015	.136	+0.05	.115	07150-07115	.142	07170-07875
5/32" BRIV® St.Steel only	19	AS REC.	.120	07170-06805	.126	+0.05	.125	07170-06825	.132	07170-06875
	20	AS REC.	.120	07170-07805	.126	+0.05	.125	07170-07825	.132	07170-07875
3/16" BRIV® Al. Alloy, Brass, Steel	21	AS REC.	.141	07150-06016	.157	+0.05	.146	07150-06116	.164	07170-06876
	22	AS REC.	.141	07150-07016	.157	+0.05	.146	07150-07116	.164	07170-07876
3/16" BRIV® St.Steel only	23	AS REC.	.153	07170-06806	.150	+0.05	.158	07170-06826	.156	07170-06876
	24	AS REC.	.153	07170-07806	.150	+0.05	.158	07170-07826	.156	07170-07876
6mm BRIV® Al. Alloy, Steel	25	AS REC.	.179	07150-06018	.165	+0.05	.184	07150-06118	.171	07150-06846
	26	AS REC.	.179	07150-07018	.165	+0.05	.184	07150-07118	.171	07150-07846

FASTENER	REF. N°	HOLE SIZE	2ND OVERSIZE MANDREL - BLUE			HOLE SIZE	3RD OVERSIZE MANDREL - RED			SPRING PART N°
			HEAD Ø	MANDREL PART N°	P MAX.		HEAD Ø	MANDREL PART N°	P MAX.	
3/32" BRIV® Brass only	13	+0.008	.079	07150-06213	.126	-	-	-	-	07170-06873
	14	+0.008	.079	07150-06213	.126	-	-	-	-	07170-06903
1/8" BRIV® Al. Alloy, Brass, Steel	15	+0.010	.102	07271-06614	.133	-	-	-	-	07150-06814
	16	+0.010	.102	07271-07614	.133	-	-	-	-	07150-07814
5/32" BRIV® Al. Alloy, Brass, Steel	17	+0.010	.120	07150-06215	.149	-	-	-	-	07170-06875
	18	+0.010	.120	07150-07215	.149	-	-	-	-	07170-07875
5/32" BRIV® St.Steel only	19	-	-	-	-	-	-	-	-	-
3/16" BRIV® Al. Alloy, Brass, Steel	21	+0.010	.151	07150-06216	.170	+0.012	.153	07150-06316	.173	07170-06876
	22	+0.010	.151	07150-07216	.170	+0.012	.153	07150-07316	.173	07170-07876
3/16" BRIV® St.Steel only	23	-	-	-	-	-	-	-	-	-
	24	-	-	-	-	-	-	-	-	-
6mm BRIV® Al. Alloy, Steel	25	+0.010	.189	07150-06218	.177	-	-	-	-	07150-06846
	26	+0.010	.189	07150-07218	.177	-	-	-	-	07150-07846

Nose Assemblies

Mandrel Head Types and 'P' Length

Mandrels for stainless steel Briv® are easily identifiable by a 'V' cut in the end of the mandrel heads.

When using curved nose jaws, mandrels have to be bent by hand to match the curvature of the nose jaw, thus ensuring good feed of fasteners.

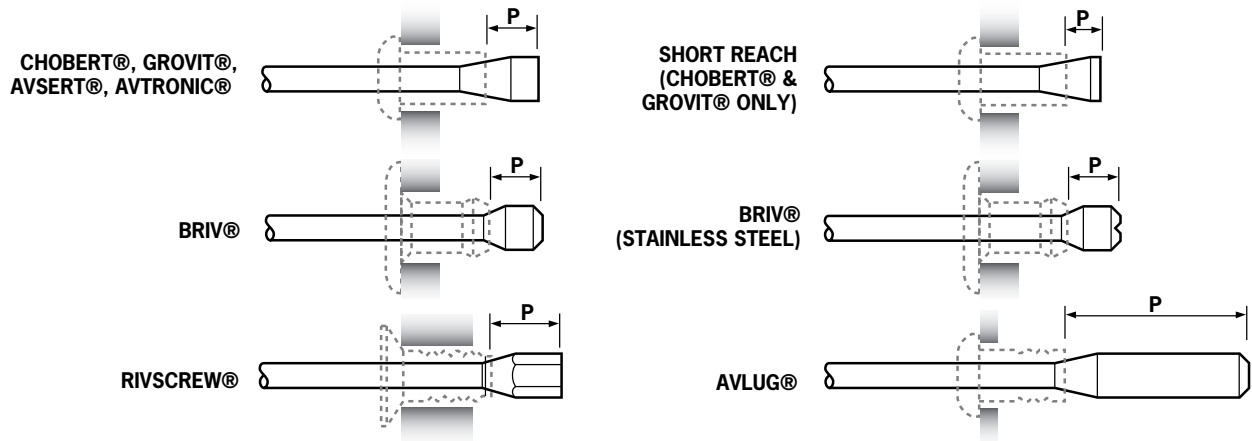

Briv® - Metric

FASTENER	REF. N°	HOLE SIZE	STANDARD MANDREL - GREEN			HOLE SIZE	1ST OVERSIZE MANDREL - YELLOW			SPRING PART N°
			HEAD Ø	MANDREL PART N°	P MAX.		HEAD Ø	MANDREL PART N°	P MAX.	
3/32" BRIV® Brass only	13	AS REC.	1.83	07150-06013	3.02	+10	1.93	07150-06113	3.12	07170-06873
	14	AS REC.	1.83	07150-06013	3.02	+10	1.93	07150-06113	3.12	07170-06903
1/8" BRIV® Al. Alloy, Brass, Steel	15	AS REC.	2.34	07271-06414	3.05	+13	2.46	07271-06514	3.20	07150-06814
	16	AS REC.	2.34	07271-07414	3.05	+13	2.46	07271-07514	3.20	07150-07814
5/32" BRIV® Al. Alloy, Brass, Steel	17	AS REC.	2.79	07150-06015	3.45	+13	2.92	07150-06115	3.61	07170-06875
	18	AS REC.	2.79	07150-07015	3.45	+13	2.92	07150-07115	3.61	07170-07875
5/32" BRIV® St. Steel only	19	AS REC.	3.05	07170-06805	3.20	+13	3.18	07170-06825	3.35	07170-06875
	20	AS REC.	3.05	07170-07805	3.20	+13	3.18	07170-07825	3.35	07170-07875
3/16" BRIV® Al. Alloy, Brass, Steel	21	AS REC.	3.58	07150-06016	3.99	+13	3.71	07150-06116	4.17	07170-06876
	22	AS REC.	3.58	07150-07016	3.99	+13	3.71	07150-07116	4.17	07170-07876
3/16" BRIV® St. Steel only	23	AS REC.	3.89	07170-06806	3.81	+13	4.01	07170-06826	3.96	07170-06876
	24	AS REC.	3.89	07170-07806	3.81	+13	4.01	07170-07826	3.96	07170-07876
6mm BRIV® Al. Alloy, Steel	25	AS REC	4.54	07150-06018	4.18	+13	4.67	07150-06118	4.34	07150-06846
	26	AS REC	4.54	07150-07018	4.18	+13	4.67	07150-07118	4.34	07150-07846

FASTENER	REF. N°	HOLE SIZE	2ND OVERSIZE MANDREL - BLUE			HOLE SIZE	3RD OVERSIZE MANDREL - RED			SPRING PART N°
			HEAD Ø	MANDREL PART N°	P MAX.		HEAD Ø	MANDREL PART N°	P MAX.	
3/32" BRIV® Brass only	13	+20	2.01	07150-06213	3.20	-	-	-	-	07170-06873
	14	+20	2.01	07150-06213	3.20	-	-	-	-	07170-06903
1/8" BRIV® Al. Alloy, Brass, Steel	15	+25	2.59	07271-06614	3.38	-	-	-	-	07150-06814
	16	+25	2.59	07271-07614	3.38	-	-	-	-	07150-07814
5/32" BRIV® Al. Alloy, Brass, Steel	17	+25	3.05	07150-06215	3.78	-	-	-	-	07170-06875
	18	+25	3.05	07150-07215	3.78	-	-	-	-	07170-07875
5/32" BRIV® St. Steel only	19	-	-	-	-	-	-	-	-	-
	20	-	-	-	-	-	-	-	-	-
3/16" BRIV® Al. Alloy, Brass, Steel	21	+25	3.84	07150-06216	4.32	+30	3.85	07150-06316	4.39	07170-06876
	22	+25	3.84	07150-07216	4.32	+30	3.85	07150-07316	4.39	07170-07876
3/16" BRIV® St. Steel only	23	-	-	-	-	-	-	-	-	-
	24	-	-	-	-	-	-	-	-	-
6mm BRIV® Al. Alloy, Steel	25	+25	4.79	07150-06218	4.49	-	-	-	-	07150-06846
	26	+25	4.79	07150-07218	4.49	-	-	-	-	07150-07846

Nose Assemblies

Avlug®, Avsert®, Avtronic® & Rivscrew® - Imperial & Metric

For mandrel or mandrel follower spring selection, follow instructions on page 19.

FASTENER	REF. N°	HOLE SIZE	STANDARD MANDREL - GREEN			HOLE SIZE	1ST OVERSIZE MANDREL - YELLOW			SPRING PART N°
			HEAD Ø	MANDREL PART N°	P MAX.		HEAD Ø	MANDREL PART N°	P MAX.	
3/32" AVLUG®	27	AS REC.	.076	07150-06603	.353	+0.05	.081	07150-06703	.478	07150-06803
	28	AS REC.	.076	07150-07603	.353	+0.03	.079	07150-07703	.368	07150-07803
1/8" AVLUG®	29	AS REC.	.098	07150-06604	.593	-	-	-	-	07150-06804
	30	AS REC.	.098	07150-07604	.593	-	-	-	-	07150-07804
2.5mm, 4-40 UNC AVSERT®	31	AS REC.	.0725	07150-06003	.145	-	-	-	-	07150-06803
3.0mm, 6-32 UNC AVSERT®	32	AS REC.	.088	07150-06004	.185	-	-	-	-	07150-06804
2.5mm AVTRONIC®	33	AS REC.	.070	07170-06025	.140	+0.03	.073	07170-06125	.140	07150-06803
	34	AS REC.	.070	07170-07025	.140	+0.03	.073	07170-07125	.140	07150-07803
2.8mm AVTRONIC®	35	AS REC.	.079	07170-06028	.150	+0.03	.082	07170-06128	.150	07170-06528
	36	AS REC.	.079	07170-06028	.150	+0.03	.082	07170-06128	.150	07170-06873
	37	AS REC.	.079	07170-07028	.150	+0.03	.082	07170-07128	.150	07170-07528
2.8mm RIVSCREW®	38	AS REC.	* .065	07271-06030	.127	-	-	-	-	07271-06630
3.0mm RIVSCREW®	39	AS REC.	* .065	07271-06030	.127	-	-	-	-	07271-06630
3.5mm RIVSCREW®	40	AS REC.	* .0825	07271-06035	.132	-	-	-	-	07271-06635
4.0mm RIVSCREW®	41	AS REC.	* .103	07271-06140	.150	-	-	-	-	07271-06640

* These Dimensions are Across Flats

FASTENER	REF. N°	HOLE SIZE	2ND OVERSIZE MANDREL - BLUE			HOLE SIZE	3RD OVERSIZE MANDREL - RED			SPRING PART N°
			HEAD Ø	MANDREL PART N°	P MAX.		HEAD Ø	MANDREL PART N°	P MAX.	
3/32" AVLUG®	27	-	-	-	-	-	-	-	-	-
	28	-	-	-	-	-	-	-	-	-
1/8" AVLUG®	29	-	-	-	-	-	-	-	-	-
	30	-	-	-	-	-	-	-	-	-
2.5mm, 4-40 UNC AVSERT®	31	-	-	-	-	-	-	-	-	-
3.0mm, 6-32 UNC AVSERT®	32	-	-	-	-	-	-	-	-	-
2.5mm AVTRONIC®	33	+0.06	.076	07170-06225	.140	-	-	-	-	07150-06803
	34	+0.06	.076	07170-07225	.140	-	-	-	-	07150-07803
2.8mm AVTRONIC®	35	+0.06	.085	07170-06228	.150	-	-	-	-	07170-06528
	36	+0.06	.085	07170-06228	.150	-	-	-	-	07170-06873
	37	+0.06	.085	07170-07228	.150	-	-	-	-	07170-07528
2.8mm RIVSCREW®	38	-	-	-	-	-	-	-	-	-
3.0mm RIVSCREW®	39	-	-	-	-	-	-	-	-	-
3.5mm RIVSCREW®	40	-	-	-	-	-	-	-	-	-
4.0mm RIVSCREW®	41	-	-	-	-	-	-	-	-	-

FASTENER	LINE N°	HOLE SIZE	STANDARD MANDREL - GREEN			HOLE SIZE	1ST OVERSIZE MANDREL - YELLOW			SPRING PART N°
			HEAD Ø	MANDREL PART N°	P MAX.		HEAD Ø	MANDREL PART N°	P MAX.	
3/32" AVLUG®	27	AS REC.	1.93	07150-06603	8.97	+1.0	2.06	07150-06703	12.14	07150-06803
	28	AS REC.	1.93	07150-07603	8.97	+1.0	2.01	07150-07703	9.35	07150-07803
1/8" AVLUG®	29	AS REC.	2.49	07150-06604	15.06	-	-	-	-	07150-06804
	30	AS REC.	2.49	07150-07604	15.06	-	-	-	-	07150-07804
2.5mm, 4-40 UNC AVSERT®	31	AS REC.	1.84	07150-06003	3.68	-	-	-	-	07150-06803
3.0mm, 6-32 UNC AVSERT®	32	AS REC.	2.24	07150-06004	4.70	-	-	-	-	07150-06804
2.5mm AVTRONIC®	33	AS REC.	1.78	07170-06025	3.56	+0.7	1.85	07170-06125	3.56	07150-06803
	34	AS REC.	1.78	07170-07025	3.56	+0.7	1.85	07170-07125	3.56	07150-07803
2.8mm AVTRONIC®	35	AS REC.	2.01	07170-06028	3.81	+0.7	2.08	07170-06128	3.81	07170-06528
	36	AS REC.	2.01	07170-06028	3.81	+0.7	2.08	07170-06128	3.81	07170-06873
	37	AS REC.	2.01	07170-07028	3.81	+0.7	2.08	07170-07128	3.81	07170-07528
2.8mm RIVSCREW®	38	AS REC.	* 1.65	07271-06030	3.23	-	-	-	-	07271-06630
3.0mm RIVSCREW®	39	AS REC.	* 1.65	07271-06030	3.23	-	-	-	-	07271-06630
3.5mm RIVSCREW®	40	AS REC.	* 2.10	07271-06035	3.35	-	-	-	-	07271-06635
4.0mm RIVSCREW®	41	AS REC.	* 2.62	07271-06140	3.81	-	-	-	-	07271-06640

* These Dimensions are Across Flats

FASTENER	LINE N°	HOLE SIZE	2ND OVERSIZE MANDREL - BLUE			HOLE SIZE	3RD OVERSIZE MANDREL - RED			SPRING PART N°
			HEAD Ø	MANDREL PART N°	P MAX.		HEAD Ø	MANDREL PART N°	P MAX.	
3/32" AVLUG®	27	-	-	-	-	-	-	-	-	-
	28	-	-	-	-	-	-	-	-	-
1/8" AVLUG®	29	-	-	-	-	-	-	-	-	-
	30	-	-	-	-	-	-	-	-	-
2.5mm, 4-40 UNC AVSERT®	31	-	-	-	-	-	-	-	-	-
3.0mm, 6-32 UNC AVSERT®	32	-	-	-	-	-	-	-	-	-
2.5mm AVTRONIC®	33	+1.5	1.93	07170-06225	3.56	-	-	-	-	07150-06803
	34	+1.5	1.93	07170-07225	3.56	-	-	-	-	07150-07803
2.8mm AVTRONIC®	35	+1.5	2.16	07170-06228	3.81	-	-	-	-	07170-06528
	36	+1.5	2.16	07170-06228	3.81	-	-	-	-	07170-06873
	37	+1.5	2.16	07170-07228	3.81	-	-	-	-	07170-07528
2.8mm RIVSCREW®	38	-	-	-	-	-	-	-	-	-
3.0mm RIVSCREW®	39	-	-	-	-	-	-	-	-	-
3.5mm RIVSCREW®	40	-	-	-	-	-	-	-	-	-
4.0mm RIVSCREW®	41	-	-	-	-	-	-	-	-	-