



# Avdel



## Instruction Manual

Pass onto user to read and keep for reference



**Hydro-Pneumatic Power Tool**

**07500 model**

AVDEL policy is one of continuous development. Specifications shown in this document may be subject to changes which may be introduced after publication. For the latest information always consult Avdel.

### SPECIFICATIONS FOR 07500 TOOL

AIR PRESSURE	■	Minimum - Maximum	■ 5.5 - 7 bar	■ 80 - 100 lbf/in <sup>2</sup>
FREE AIR VOLUME REQUIRED	■	@ 5.5 bar / 80 lbf/in <sup>2</sup>	■ 5.7 litres	■ .20 ft <sup>3</sup>
STROKE	■	Minimum	■ 12.7 mm	■ .50 in
PULL FORCE	■	@ 5.5 bar / 80 lbf/in <sup>2</sup>	■ 15.6 kN	■ 3500 lbf
CYCLE TIME	■	Approximately	■ 1 second	■
NOISE LEVEL	■		■ 84.7 dB(A)	■
WEIGHT	■	Without nose equipment	■ 3.85 kg	■ 8.47 lb
VIBRATION	■	Less than	■ 2.5 m/s <sup>2</sup>	■ 8 ft/s <sup>2</sup>

## SAFETY

General	2
Specific to 07500 Tool	3

## INTENT OF USE

General	4
Tool Dimensions	4

## PUTTING INTO SERVICE

Air Supply	5
Operating Procedure	5
Accessories	6 - 7

## NOSE ASSEMBLIES

Selection/Fitting/Serviceing/Components	8-10
---	------

## SERVICING

Regular Servicing	11
Maintenance	12-14
General Assembly & Parts List	16-17

## PRIMING

Priming Oil Details	18
Priming Procedure	18-19

## FAULT DIAGNOSIS

Fault Diagnosis Table	20
-----------------------	----

# S A F E T Y

This instruction manual must be read with particular attention to the following safety rules, by any person installing, operating, or servicing this tool.

⚠ DO NOT USE OUTSIDE THE DESIGN INTENT.

⚠ DO NOT USE EQUIPMENT WITH THIS TOOL/MACHINE OTHER THAN THAT RECOMMENDED AND SUPPLIED BY AVDEL.

⚠ ANY MODIFICATION UNDERTAKEN BY THE CUSTOMER TO THE TOOL/MACHINE, NOSE ASSEMBLIES, ACCESSORIES OR ANY EQUIPMENT SUPPLIED BY AVDEL OR THEIR REPRESENTATIVES, SHALL BE THE CUSTOMER'S ENTIRE RESPONSIBILITY. AVDEL WILL BE PLEASED TO ADVISE UPON ANY PROPOSED MODIFICATION.

⚠ THE TOOL/MACHINE MUST BE MAINTAINED IN A SAFE WORKING CONDITION AT ALL TIMES AND EXAMINED AT REGULAR INTERVALS FOR DAMAGE AND FUNCTION BY TRAINED COMPETENT PERSONNEL. ANY DISMANTLING PROCEDURE SHALL BE UNDERTAKEN ONLY BY PERSONNEL TRAINED IN AVDEL PROCEDURES. DO NOT DISMANTLE THIS TOOL/MACHINE WITHOUT PRIOR REFERENCE TO THE MAINTENANCE INSTRUCTIONS. CONTACT AVDEL WITH YOUR TRAINING REQUIREMENTS.

⚠ THE TOOL/MACHINE SHALL AT ALL TIMES BE OPERATED IN ACCORDANCE WITH RELEVANT HEALTH AND SAFETY LEGISLATION. IN THE U.K. THE "HEALTH AND SAFETY AT WORK ETC. ACT 1974" APPLIES. ANY QUESTION REGARDING THE CORRECT OPERATION OF THE TOOL/MACHINE AND OPERATOR SAFETY SHOULD BE DIRECTED TO AVDEL.

⚠ THE PRECAUTIONS TO BE OBSERVED WHEN USING THIS TOOL/MACHINE MUST BE EXPLAINED BY THE CUSTOMER TO ALL OPERATORS.

⚠ ALWAYS DISCONNECT THE AIRLINE FROM THE TOOL/MACHINE INLET BEFORE ATTEMPTING TO ADJUST, FIT OR REMOVE A NOSE ASSEMBLY.

⚠ DO NOT OPERATE A TOOL/MACHINE THAT IS DIRECTED TOWARDS ANY PERSON(S).

⚠ ALWAYS ADOPT A FIRM FOOTING OR A STABLE POSITION BEFORE OPERATING THE TOOL/MACHINE.

⚠ ENSURE THAT VENT HOLES DO NOT BECOME BLOCKED OR COVERED AND THAT HOSES ARE ALWAYS IN GOOD CONDITION.

In addition to the general safety rules opposite, the following specific safety points must also be observed:

- ⚠ THE OPERATING PRESSURE SHALL NOT EXCEED 7 BAR - 100 LBF/IN<sup>2</sup>.
- ⚠ DO NOT OPERATE THE TOOL WITHOUT FULL NOSE EQUIPMENT IN PLACE.
- ⚠ CARE SHALL BE TAKEN TO ENSURE THAT SPENT PINTAILS ARE NOT ALLOWED TO CREATE A HAZARD.
- ⚠ THE TOOL MUST BE FITTED WITH AN UNDAMAGED PINTAIL DEFLECTOR BEFORE OPERATING.
- ⚠ IF THE TOOL IS USED IN THE VERTICAL NOSE DOWNWARD POSITION, THE PINTAIL DEFLECTOR SHOULD BE ROTATED UNTIL THE APERTURE IS FACING AWAY FROM THE OPERATOR AND OTHER PERSON(S) WORKING IN THE VICINITY.
- ⚠ WHEN USING THE TOOL, THE WEARING OF SAFETY GLASSES IS REQUIRED BOTH BY THE OPERATOR AND OTHERS IN THE VICINITY TO PROTECT AGAINST PIN EJECTION, SHOULD A FASTENER BE PLACED 'IN AIR'. WE RECOMMEND WEARING GLOVES IF THERE ARE SHARP EDGES OR CORNERS ON THE APPLICATION.
- ⚠ TAKE CARE TO AVOID ENTANGLEMENT OF LOOSE CLOTHES, TIES, LONG HAIR, CLEANING RAGS ETC. IN THE MOVING PARTS OF THE TOOL WHICH SHOULD BE KEPT DRY AND CLEAN FOR BEST POSSIBLE GRIP.
- ⚠ WHEN CARRYING THE TOOL FROM PLACE TO PLACE KEEP HANDS AWAY FROM THE TRIGGER/LEVER TO AVOID INADVERTENT START UP.
- ⚠ EXCESSIVE CONTACT WITH HYDRAULIC OIL SHOULD BE AVOIDED. TO MINIMIZE THE POSSIBILITY OF RASHES, CARE SHOULD BE TAKEN TO WASH THOROUGHLY.

# CONTENT OF USE

The hydro-pneumatic 07500 type tool is designed to place Avdelok Pins and collars at high speed making it ideal for batch or flow-line assembly in a wide variety of applications throughout all industries.

For a complete tool, order a base tool part number 07500-00200 and select a nose assembly to suit your application from the Nose Assemblies section page 8.

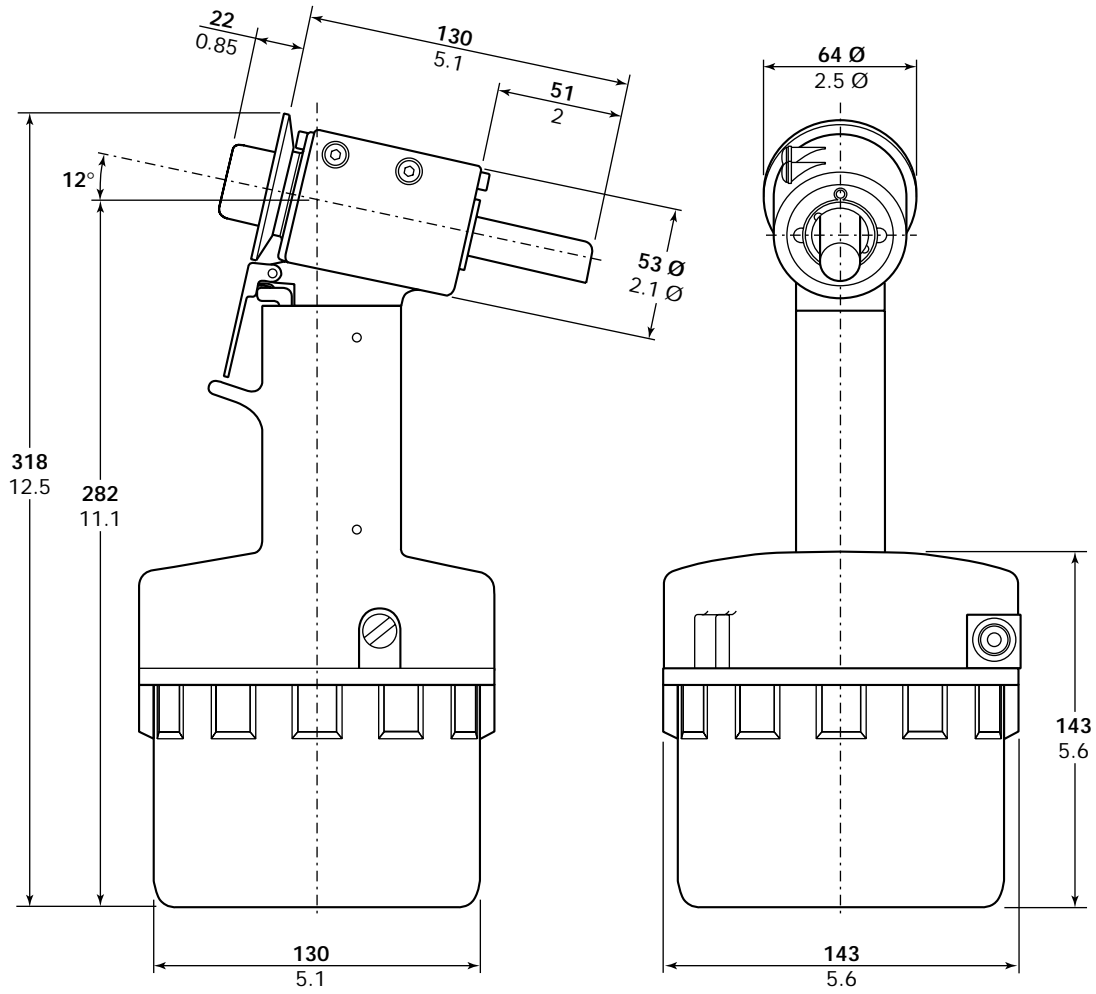

*Dimensions shown in bold are millimetres. Other dimensions are in inches.*

# PUTTING INTO SERVICE

## AIR SUPPLY

All tools are operated with compressed air at an optimum pressure of 5.4 bar. We recommend the use of pressure regulators and automatic oiling/filtering systems on the main air supply. These should be fitted within 3 metres of the tool (see diagram below) to ensure maximum tool life and minimum tool maintenance.

Air supply hoses should have a minimum working effective pressure rating of 150% of the maximum pressure produced in the system or 10 bar, whichever is the highest. Air hoses should be oil resistant, have an abrasion resistant exterior and should be armoured where operating conditions may result in hoses being damaged. All air hoses MUST have a minimum bore diameter of 6.4 millimetres or  $\frac{1}{4}$  inch.

Read servicing daily details page 11.

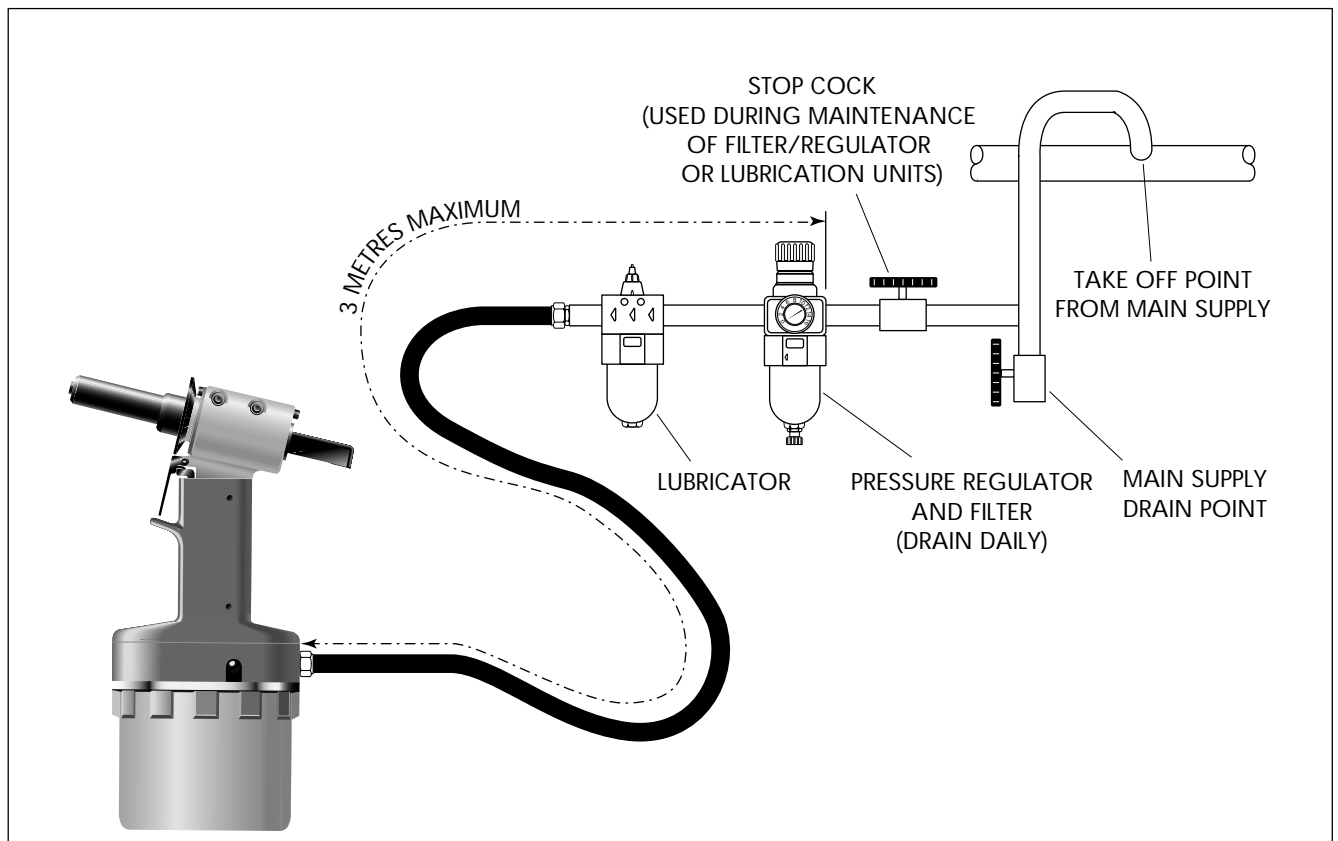

## OPERATING PROCEDURE

- Ensure that the correct nose assembly is fitted.
- Connect the tool to the air supply.
- Push the Avdelok pin through the application hole .
- Place the collar on the pin (orientation as shown right).
- Keeping the head of the pin against the application, push the tool onto the protruding pin tail.
- Fully operate the trigger. One cycle will ensure that the collar is swaged into the lock grooves of the pin and the pin breaks at the breaker groove.
- Release the trigger. The tool completes its cycle by pushing itself off the collar and ejecting the pin tail at the rear.

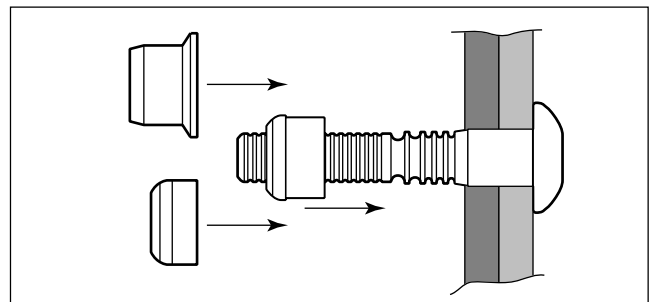

## ACCESSORIES

These are the accessories available for the 07500-00200 tool. Three of which are to make the connection with the air supply.

**Double Male Connector**  
part n° 07005-00041

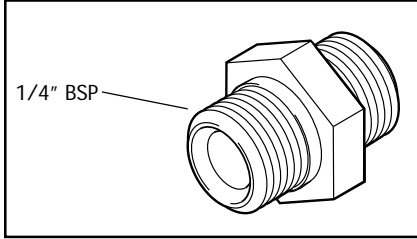

**Extension for 3/16" (4.8mm)**  
part n° 07500-02400



**Extension for 1/4" (6.4mm)**  
part n° 07500-02300

**Hose Assembly**  
part n° 07008-000324

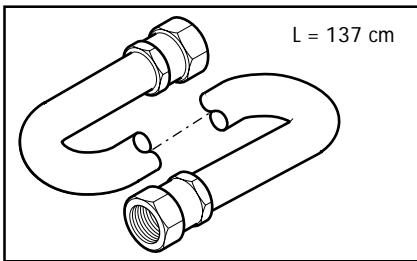

**Pintail Collector Unit**  
Part n° 07500-06600

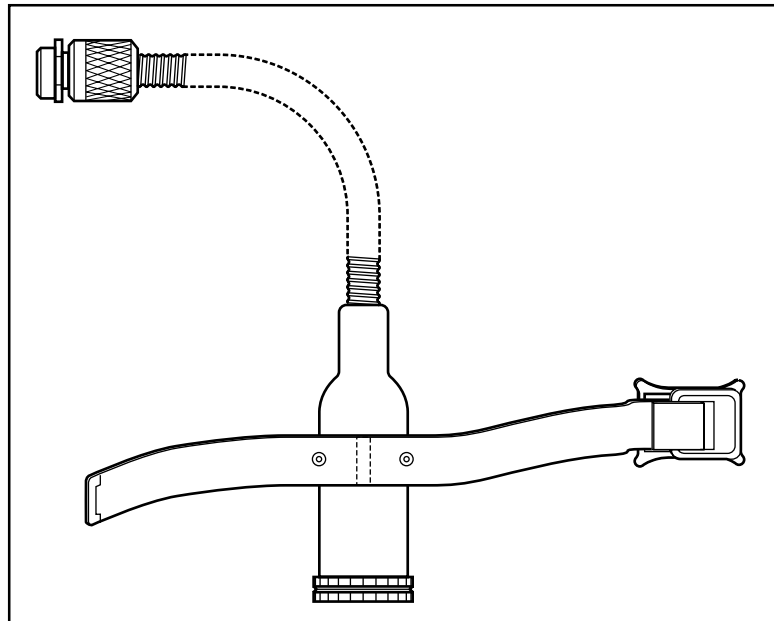

**Hose Connector**  
part n° 07005-00276

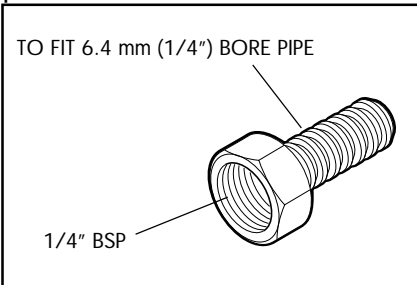

## COLLAR SPLITTERS

You can order collar splitters to cut the collars off placed 3/16" and 1/4" Avdelok and 1/4" Maxlok. The ones shown below left are for cutting 3/16" or 1/4" Avdelok collars, the one shown below right is for 1/4" Maxlok collars.

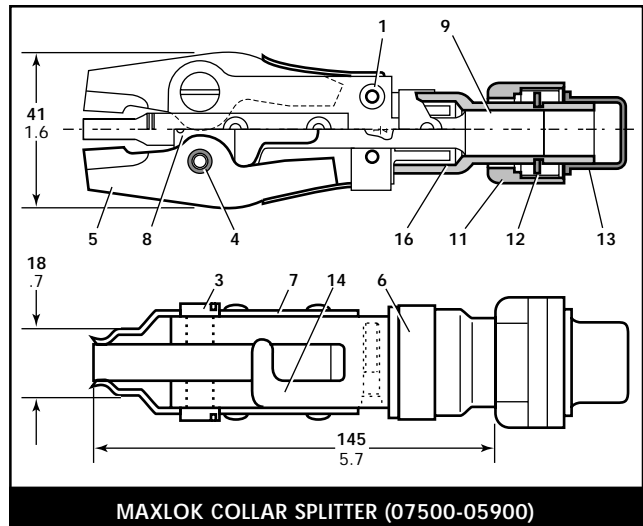
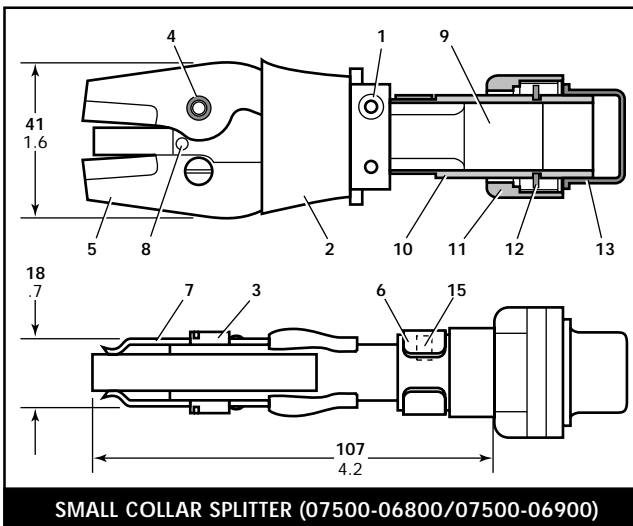



## COLLAR SPLITTERS - COMPONENT PART NUMBERS

ITEM N°	DESCRIPTION	<sup>3</sup> / <sub>16</sub> " COLLAR SPLITTER 07500-06800	<sup>1</sup> / <sub>4</sub> " COLLAR SPLITTER 07500-06900	<sup>1</sup> / <sub>4</sub> " MAXLOCK COLLAR SPLITTER 07500-05900	QTY
1	SCREW	07001-00004	07001-00004	07001-00142	2
2	SLEEVE	07210-02012	07210-02012	-	1
3	BLADE PIN	07210-02014	07210-02014	07220-03712	2
4	BLADE PIN SCREW	07210-02015	07210-02015	07220-03713	2
5	BLADE	07210-02016	07210-02104	07500-05901	2
6	SPRING CLIP	07500-08000	07500-08000	07220-04500	1
7	BLADE CARRIER ASSEMBLY	07210-02500	07210-02600	07500-07900	2
8	SPACER PIN	07210-02703	07210-02703	07220-03714	1
9	CAM	07500-06801	07500-06801	07500-05803	1
10	OUTER SLEEVE	07500-06803	07500-06803	-	1
11	NOSE RETAINING NUT	07500-00212	07500-00212	07500-00212	1
12	CIRCLIP	07004-00041	07004-00041	07004-00041	1
13	CAP	07007-00076	07007-00076	07007-00076	1
14	BLADE SPRING	-	-	07220-03706	2
15	INDEPENDANT RETAINING PIN	07005-08003	07005-08003	-	1
16	SLEEVE ADAPTOR	-	-	07500-05802	1

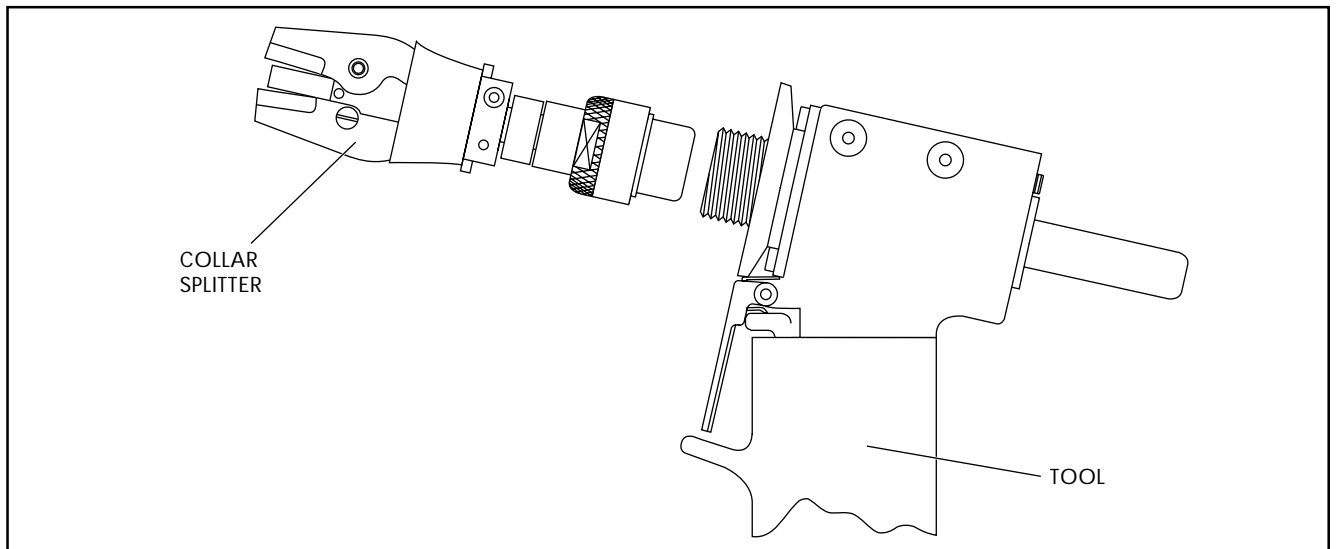

- To fit collar splitters, first disconnect the air supply to the tool.
- Remove the nose assembly, if fitted.
- Lubricate the collar splitter cam faces, bearing faces and any moving parts with Moly Lithium Grease.
- Screw the cam onto the head piston of base tool.
- Tighten the nose retaining nut 11 onto the front of base tool and tighten with a spanner\*.
- To operate, push the collar splitter hard over the collar and then operate the trigger.

\* refers to items included in the Avdel service kit. For complete list see page 11.

# NOSE ASSEMBLIES

There are two types of nose assemblies available, straight and offset. Choose the type most suitable according to the access restrictions on your application. It is essential that the correct nose assembly is fitted prior to operating the tool.

Dimensions shown in bold are millimetres. Other dimensions are in inches.

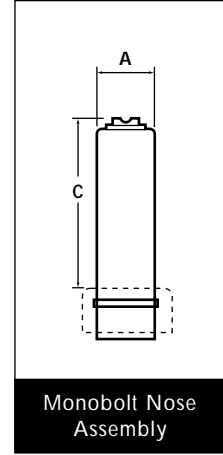
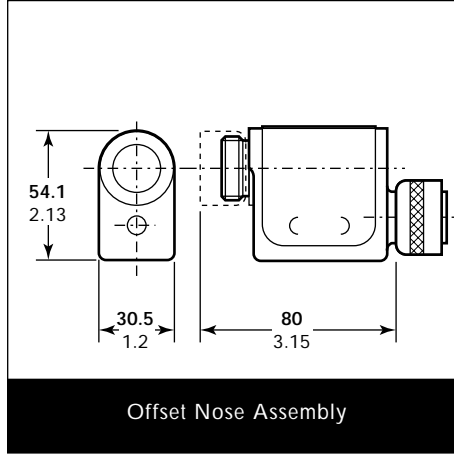
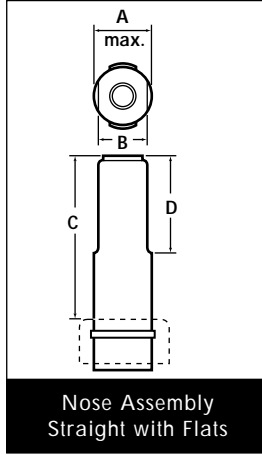
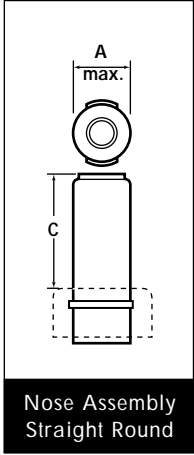

O7500 NOSE ASSEMBLY SELECTION										
FASTENER SIZE	NOSE ASSEMBLY DESCRIPTION	A		B		C		D		NOSE ASSY. PART N°
		mm	inch	mm	inch	mm	inch	mm	inch	
<b>AVDELOK</b>										
<b>3/16 (4.8)</b>	Nose Assembly with Flats	20.7	.813	15.88	.625	67.82	2.67	25.4	1.000	07500-02000
	Nose Assembly with Flats	20.7	.813	15.88	.625	67.82	2.67	25.4	1.000	07500-02100
	Long Nose Assembly with Flats	20.7	.813	17.27	.680	174	6.85	25.4	1.000	07500-03000
<b>1/4 (6.4)</b>	Nose Assembly Stepped with Flats	20.7	.813	15.88	.625	70.10	2.76	27.69	1.090	07500-03400
	Nose Assembly with Flats for Avdelok only	20.7	.813	15.88	.625	75.44	2.97	25.4	1.000	07500-07500
<b>MONOBOLT</b>										
<b>1/4 (6.4)</b>	Monobolt Nose Assembly	20.7	.813	-	-	70.62	2.78	-	-	07497-03000

Stepped anvils give a less severe deformation of the collars thus allowing placing of Avdeloks in softer materials like plastics, wood etc.

## FITTING INSTRUCTIONS

### IMPORTANT

The air supply must be disconnected when fitting or removing nose assemblies unless specifically instructed otherwise.

Nose assemblies must be assembled before fitting. Offset nose assemblies are always supplied assembled.

- To assemble straight nose assemblies, lightly coat the jaws with Moly Lithium grease.
- Assemble spring guide 4 and spring 6 and stand on end on a flat even surface.
- Fit spring guide 4 into spring 6.
- Balance the three chuck jaws 3 on the spring guide 4 (using a spent pintail to aid positioning if necessary).
- Carefully lower chuck collet 2 over the assembled components. Invert assembly and screw in screwed spring guide 5. Tighten fully.
- Remove nose retaining nut (item 81 of base tool pages 14 - 15) from front of base tool.
- Screw the assembled chuck collet onto the tool using a spanner\*.
- Push anvil 1 over the chuck collet.
- Slide nose retaining nut over anvil 1 and screw onto front of tool.

To fit Offset Head, proceed as follows:

- Remove nose retaining nut (item 81 of base tool pages 14 - 15) from front of base tool.
- Screw on offset head onto the head piston of base tool then tighten the retaining nut 7 which is part of the offset head.
- Insert screw (item 4 page 11) through rear of head of tool into the coupling tube 5 of the offset head. Turn offset head to desired position and lock by tightening screw 4.
- Fit selected nose assembly to offset head by screwing assembled chuck collet onto operating arm extension 10 of offset head and tighten with a spanner
- Push anvil 1 over the chuck collet.
- Slide nose retaining nut (previously removed from front of base tool) over anvil 1 and screw onto front of tool.

- To assemble monobolt nose assemblies, lightly coat the jaws with Moly Lithium grease.
- Assemble spring guide 4 and spring 6 and stand on end on a flat even surface.
- Fit spring guide 4 into spring 6.
- Balance the three chuck jaws 3 on the spring guide 4 (using a spent stem to aid positioning if necessary).
- Carefully lower chuck collet 2 over the assembled components. Invert assembly and screw in screwed spring guide 5.
- Remove nose retaining nut (item 81 of base tool pages 14 - 15) from front of base tool.
- Screw the assembled chuck collet onto the tool using a spanner\*.
- Push anvil case 1 over the chuck collet.
- Slide nose retaining nut over anvil case 1 and screw onto front of tool.
- Screw nose tip 10 into anvil case 1.

## SERVICING INSTRUCTIONS

Nose assemblies should be serviced at weekly intervals.

- For straight nose assemblies, remove using the reverse procedure to the 'Fitting Instructions'.
- Particularly check wear on jaws.
- Ensure spring and spring guides (if fitted) are not worn or distorted.
- Ensure anvil 1 is not worn or cracked.
- To dismantle offset head use the reverse procedure to the fitting instructions.
- Assemble in reverse order to dismantling.

\* refers to items included in the Avdel service kit. For complete list see page 11.

## NOSE ASSEMBLY COMPONENTS

Each nose assembly represents a unique assembly of components which can be ordered individually. Component numbers refer to the illustrations. We recommend some stock as items will need regular replacement. Read the Nose Assemblies servicing instructions on page 9 carefully.

COMPONENT PART NUMBERS OF ROUND, HORIZONTAL FLATS AND VERTICAL FLATS STRAIGHT NOSE ASSEMBLIES									
DESCRIPTION	ANVIL	CHUCK COLLET	CHUCK JAWS	SPRING GUIDE	SCREWED SPRING GUIDE	SPRING	FRICTION RING (COLLET)	NOSE RETAINING CAP	INNER EXTENSION
ITEM N°	1	2	3	4	5	6	7	8	9
QTY	1	1	1 SET	1	1	1	1	1	1
NOSE ASSY									
07500-02000	07500-03100	07500-02002	07220-02102	07500-02003	07500-02004	07500-02005	07500-02006	07007-00076	-
07500-02100	07500-03200	07500-02102	07220-02302	07500-02003	07500-02004	07500-02005	07500-02006	07007-00076	-
07500-03000	07500-03300	07500-02102	07220-02302	07500-02003	07500-02004	07500-02005	07500-02006	07007-00076	07500-03002
07500-03400	07500-03500	07500-03502	07220-02302	07500-02003	07500-02004	07500-02005	07500-02006	07007-00076	-
07500-07500	07500-07600	07500-07602	07220-02302	07500-02003	07500-02004	07500-02005	07500-02006	07007-00076	-

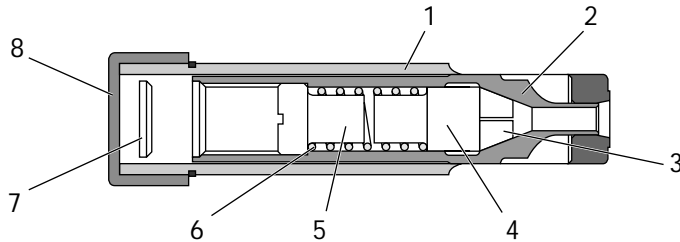

COMPONENT PART NUMBERS OF MONOBOLT NOSE ASSEMBLIES			
ITEM N°	DESCRIPTION	NOSE ASSY 07497-03000	QTY
1	ANVIL CASE	07497-03201	1
2	CHUCK COLLET	07497-03003	1
3	CHUCK JAWS	07497-03002	1 SET
4	SPRING GUIDE	07500-02003	1
5	SCREWED SPRING GUIDE	07500-02004	1
6	SPRING	07500-02005	1
7	FRICTION RING (COLLET)	07500-02006	1
8	NOSE RETAINING CAP	07007-00076	1
10	NOSE TIP	07497-03202	1
11	EXTERNAL CIRCLIP	07004-00041	1

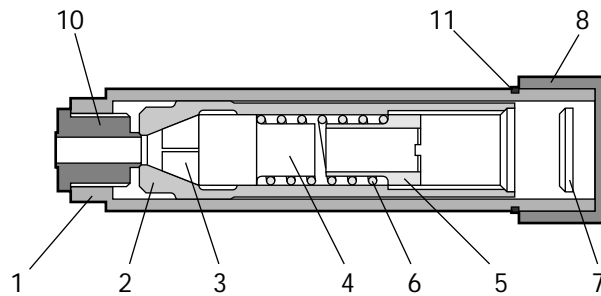

COMPONENT PART NUMBERS OF OFFSET HEAD ASSEMBLIES			
ITEM N°	DESCRIPTION	NOSE ASSY 07500-02200	QTY
1	GUIDE TUBE	07500-02209	1
2	EXTERNAL CIRCLIP	07004-00041	1
3	NOSE RETAINING NUT	07500-00212	1
4	10-32 UNF SOCKET SCREW	07001-00011	1
5	COUPLING TUBE	07500-02206	1
6	BEARING PAD (OFFSET ADAPTOR)	07500-02207	1
7	PIN	07007-00064	1
8	OFFSET CASING	07500-02210	1
9	OPERATING ARM	07500-02211	1
10	OPERATING ARM EXTENSION	07500-02205	1
11	FRICTION RING (RETAINING RING)	07500-00313	1
12	GUARD	07500-02208	1

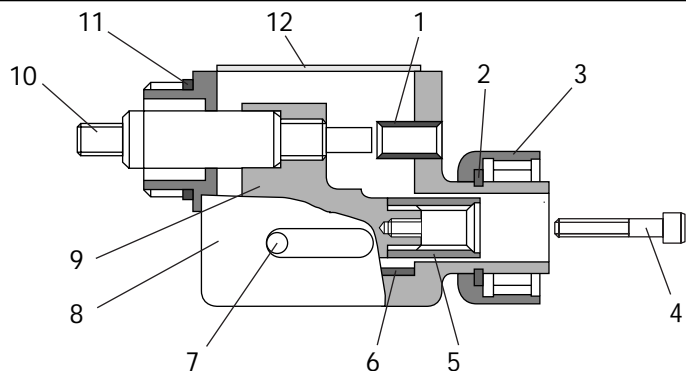

# SERVICING THE TOOL

Regular servicing should be carried out and a comprehensive inspection performed annually or every 500000 cycles, whichever is sooner.

## IMPORTANT

The employer is responsible for ensuring that tool maintenance instructions are given to the appropriate personnel.  
The operator should not be involved in maintenance or repair of the tool unless properly trained.

## DAILY

- Daily, before use or when first putting the tool into service, pour a few drops of clean, light lubricating oil into the air inlet of the tool if no lubricator is fitted on air supply. If the tool is in continuous use, the air hose should be disconnected from the main air supply and the tool lubricated every two to three hours.
- Check for air leaks. If damaged, hoses and couplings should be replaced by new items.
- If there is no filter on the pressure regulator, bleed the air line to clear it of accumulated dirt or water before connecting air hose to tool. If a filter is fitted, drain it.
- Check that the nose equipment is correct.
- Ensure deflector 52 is fitted to the tool.
- Check that the stroke of the tool meets the minimum specification (inside front page). It is the distance travelled by the chuck collet with nose equipment fitted, measured before trigger is pressed and when trigger is fully depressed.

## WEEKLY

- Check for oil leaks and air leaks on air supply hose and fittings.
- Dismantle and clean the nose assembly, with special attention to the jaws (lubricate with Moly Lithium grease EP 3573 before refitting).
- Lubricate the cam faces and bearing faces on the collar splitters with Moly Lithium grease EP 3753.

Grease can be ordered as a single item, the part number is shown in the service kit below.

MOLY LITHIUM GREASE EP 3753 SAFETY DATA	
<p><b>FIRST AID</b> SKIN: As the grease is completely water resistant it is best removed with an approved emulsifying skin cleaner.</p> <p>INGESTION: Make the individual drink 30ml Milk of Magnesia, preferably in a cup of milk.</p> <p>EYES: Irritant but not harmful. Irrigate with water and seek medical attention.</p> <p><b>ENVIRONMENT</b> Scrape up for burning or disposal on approved site.</p>	<p><b>FIRE</b> FLASH POINT: Above 220°C. Not classified as flammable. Suitable extinguishing media: CO<sub>2</sub>, Halon or water spray if applied by an experienced operator.</p> <p><b>HANDLING</b> Use barrier cream or oil resistant gloves</p> <p><b>STORAGE</b> Away from heat and oxidising agent.</p>

## MAINTENANCE

For all servicing we recommend the use of the service kit (part number 07900-05000).

SERVICE KIT		
ITEM PART N°	DESCRIPTION	N° OFF
07900-00133	OFFSET ALLEN KEY	1
07900-00136	SPANNER	1
07900-00137	3/16" TOMMY BAR	1
07900-00138	COMBINATION TOOL FOR HEAD CYLINDER	1
07900-00334	PRIMING PUMP	1
07900-00009	3/32" ALLEN KEY	1
07900-00174	3/16" ALLEN KEY	1
07900-00013	1/8" ALLEN KEY	1
07900-00078	5/32" ALLEN KEY	1
07900-00173	CIRCLIP PLIERS	

SERVICE KIT (Continued)		
ITEM PART N°	DESCRIPTION	N° OFF
07900-00175	5/16" x 1/4" SPANNER	1
07900-00164	CIRCLIP PLIERS	1
07900-00176	27mm x 23mm SPANNER	1
07900-00163	5/64" ALLEN KEY	1
07900-00008	7/16" x 1/2" SPANNER	1
07900-00237	7/16" SPANNER	1
07900-00370	SPANNER	1
07900-00369	SPANNER	1
07900-00382	SCREWDRIVER (TUBULAR)	1
07900-00161	CIRCLIP PLIERS	1

Every 500,000 cycles the tool should be completely dismantled and new components should be used where worn, damaged or when recommended. All 'O' rings and seals should be renewed and lubricated with Moly Lithium grease EP 3753 before assembling.

### IMPORTANT

Safety Instructions appear on pages 2 & 3.

The employer is responsible for ensuring that tool maintenance instructions are given to the appropriate personnel.  
The operator should not be involved in maintenance or repair of the tool unless properly trained.

The airline must be disconnected before any servicing or dismantling is attempted, unless specifically instructed otherwise. It is recommended that any dismantling operation be carried out in clean conditions. Item numbers in bold refer to the general assembly drawing and parts list pages 14 and 15. Before proceeding with dismantling, empty the oil from the tool into a suitable container. Prior to dismantling the tool it is necessary to remove the nose assembly.

For total tool servicing we advise that you proceed with dismantling of sub-assemblies in the order shown page below.

### STANDARD NOSE ASSEMBLY

- Unscrew nose retaining nut **81** and pull off the integral anvil.
- Pull off rear pin tail deflector **63**.
- Using combination tool for head cylinder\* to hold head piston, unscrew the chuck collet using spanner\*.
- Unscrew the spring guide and remove the spring, spring guide and jaws.
- Removal of other non-standard nose assemblies follow a similar procedure, (refer to nose equipment section pages 8 - 11).

## TRIGGER AND VALVE ROD

- Remove six screws **84** and spring washers **85** from covers **83** & **86** using an Allen key\*.
- Remove covers **83** & **86**, foam silencers and valve operating rod **79**.
- Drift out pin **7** and remove trigger sub-assembly **6**.
- Assemble in reverse order to dismantling.
- When fitting the silencers, place foam in position. Hold in position and secure left hand cover **83**. Keeping foam silencers in position, fit right hand cover **86**, ensuring foam protrudes from the cover.

## AIR VALVE

- Unscrew rear valve seat **31** using spanner\* and remove, together with 'O' ring **37** and spring (air valve) **32**.
- Unscrew front valve seat **38** using spanner\* and remove, together with 'O' ring **37**.
- Using air valve spindle spanner\* and Allen key\* remove screw **33**, valve 'O' ring washers **30**, 'O' rings **34**, valve 'O' ring spacer **36**, valve stem **35** and stem extension **39**.
- Assemble in reverse order to dismantling.
- Valve setting procedure is described later.

## OIL RESERVOIR

- Remove heavy duty valve cap **59**.
- Using a tubular box wrench\* unscrew and remove priming nipple **58** and schrader valve **60** together with bonded seal **61**, (Some oil will be ejected when the nipple is removed).
- Unscrew reservoir valve assembly **26** and remove together with 'O' rings **25** & **27**.
- Lift out reservoir piston assembly **28** and spring **29**.
- Assemble in reverse order to dismantling.

## AIR CYLINDER

Before any dismantling has been performed, connect airline to the tool and operate the trigger. With the trigger held pressed, disconnect airline.

- Remove covers **83** & **86** and valve operating rod **79** as described earlier.
- Remove flexible coupling, double male connector **56** and copper washer **55**.
- Using offset lock wrench\*, remove screws **73** and separate air cylinder **68** from cylinder head assembly **24**.
- Remove head gasket **74** and 'O' ring **54**.
- Remove external circlip **70** using external circlip pliers\*, and pull off piston buffer **69**.
- Assemble in reverse order to dismantling.

\* refers to items included in the Avdel service kit. For complete list see page 11.

## AIR PISTON ASSEMBLY

- Ensure oil is drained from the tool.
  - Remove air cylinder **68** as described earlier.
  - Using external circlip pliers\* free circlip **48** and drop out piston buffer **50**.
  - Using an Allen key\* unscrew four screws **67** and separate cylinder head assembly **24** from head and handle sub-assembly **1**.
  - Separate air piston assembly **40** from cylinder head assembly **24** by gently tapping out handle insert **51**.
  - Unscrew kaylok nut **46** using a spanner\* and remove from intensifier rod assembly **52** the following: piston insert **47**, external circlip **48**, piston buffer **69**, insert retaining plate **43**, gasket **65**, 'O' ring **71**, 'H' ring seal **45**, air bleed insert **44**, handle insert **51**, spiral back up ring **42**, square seal **41**, 'O' ring **76** and anti extrusion ring **75**.
  - Remove 'O' ring **54** and head gasket **74** from cylinder head assembly **24**.
  - The intensifier rod valves are pre-set and should not be tampered with.
- Assemble in reverse order to dismantling.

## HEAD CYLINDER

- Ensure that the head piston is in the forward position before proceeding to dismantle.
  - Pull off rear pin tail deflector **63**.
  - Release the lock on insert retainer **21** by loosening screw **2** using an Allen key\*.
  - Using combination tool for head cylinder\* unscrew and remove insert retainer **21**.
  - Pull out head piston **12** together with seal housing **20**. Taking care not to damage the head bores.
  - Pull off front pin tail deflector **15**.
  - Unscrew screws **16** using an Allen key\* and remove head end cap **14** and wiper ring **80**.
  - Remove internal circlip **8** using internal circlip pliers\*.
  - Remove retaining washer **9**, square seal **10** and spiral back up ring **11**.
- Assemble in reverse order to dismantling.

## AIR VALVE SETTING

- To set the air valve (tool fully assembled), unscrew front valve seat **38** and rear valve seat **31** a few turns.
- Connect airline to the tool. Air should now leak through front valve seat **38**.
- Using spanner (front valve seat)\*, screw in front valve seat **38** until 'O' ring just seats and air leak ceases.
- Push valve stem **35** fully back. Air should now be leaking through rear valve seat **31**.
- With valve stem **35** held fully back, screw in rear valve seat **31** using spanner\* until 'O' ring just seats and air leak ceases.

### I M P O R T A N T

Check the tool against daily and weekly servicing.

Priming is **ALWAYS** necessary after the tool has been dismantled and prior to operating.





# GENERAL ASSEMBLY OF BASE TOOL 07500-00200

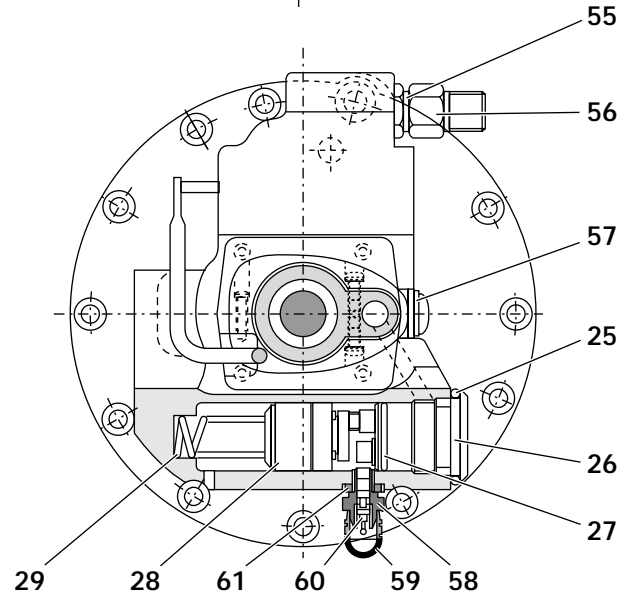
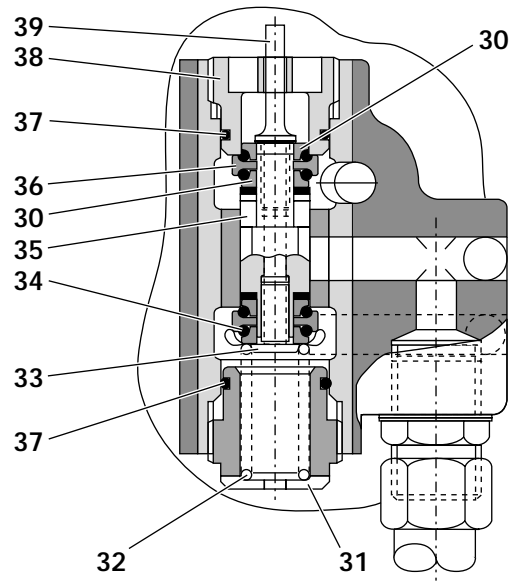
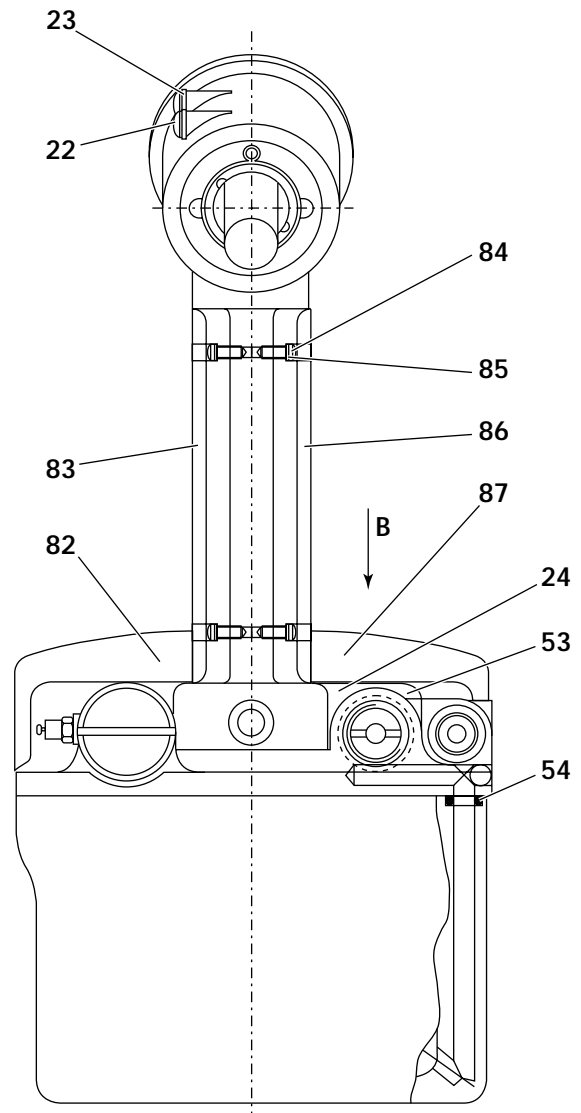
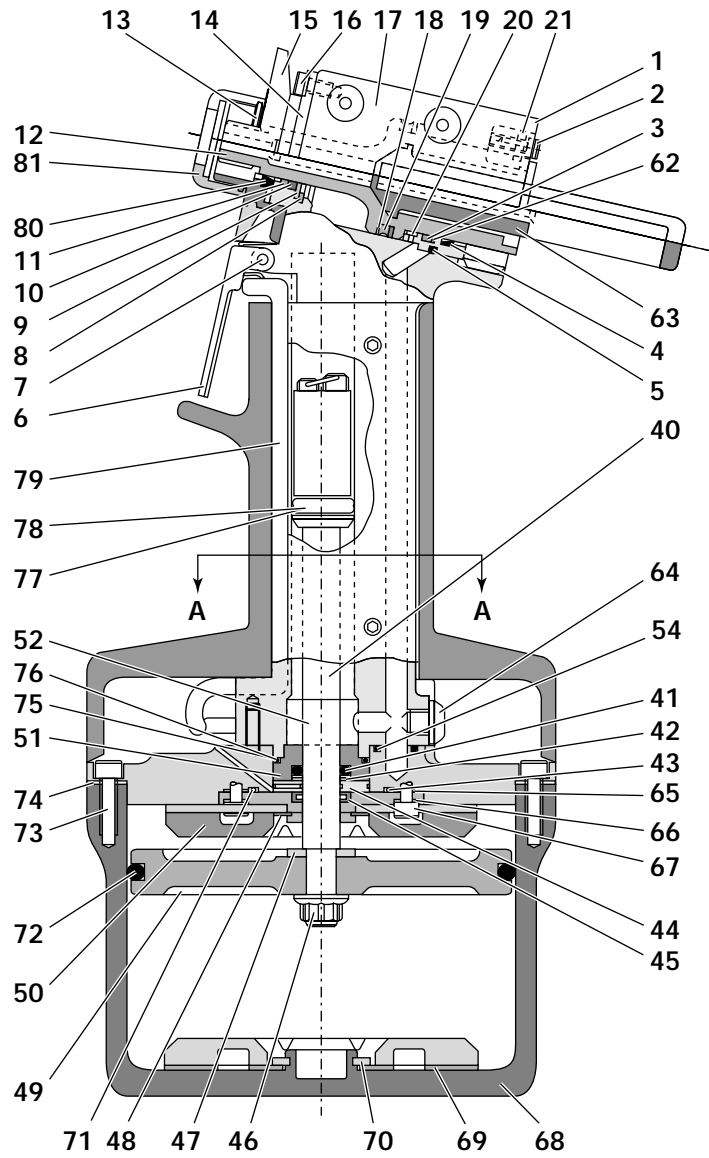

VIEW ON B

SECTION A-A  
WITH HEAD REMOVED

**07500-00200 PARTS LIST**

ITEM	PART N°	DESCRIPTION	QTY	SPARES	ITEM	PART N°	DESCRIPTION	QTY	SPARES
1	07500-01900	HEAD & HANDLE SUB-ASSY	1	-	45	07003-00087	● SEAL	1	1
2	07001-00004	● SCREW	1	1	46	07002-00017	● NUT	1	1
3	07003-00108	● SEAL	1	1	47	07500-00705	● PISTON INSERT	1	-
4	07003-00101	● WIPER RING	1	5	48	07004-00038	● CIRCLIP	1	1
5	07003-00082	● 'O' RING	1	1	49	07500-00706	● AIR PISTON	1	-
6	07500-00800	● TRIGGER SUB-ASSY	1	-	50	07500-00203	● PISTON BUFFER	1	1
7	07007-00063	● PIN	1	5	51	07500-00702	● HANDLE INSERT	1	-
8	07004-00039	● CIRCLIP	1	1	52	07500-01400	● INTENSIFIER ROD ASSY	1	-
9	07500-00304	● RETAINING WASHER	1	1	53	07500-01700	CYLINDER HEAD SUB-ASSY	1	-
10	07003-00107	● SEAL	1	1	54	07003-00001	'O' RING	2	2
11	07003-00096	● SPIRAL BACK UP RING	1	1	55	07005-00015	COPPER WASHER	1	2
12	07500-00306	● HEAD PISTON	1	-	56	07500-00041	DOUBLE MALE CONNECTOR	1	1
13	07500-00313	● FRICTION RING	1	5	57	07003-00098	SEAL	1	5
14	07500-00316	● HEAD END CAP	1	-	58	07500-00215	PRIMING NIPPLE	1	1
15	07500-00310	● FRONT PINTAIL DEFLECTOR	1	5	59	07007-00284	VALVE CAP	1	2
16	07001-00115	● SCREW	3	3	60	07005-00088	VALVE	1	1
17	07500-01901	● HANDLE	1	-	61	07003-00099	SEAL	1	1
18	07003-00014	● SPIRAL BACK UP RING	2	2	62	07003-00080	BACKUP RING	1	1
19	07003-00093	● SEAL	1	1	63	07500-04100	REAR PINTAIL DEFLECTOR	1	1
20	07500-00314	● SEAL HOUSING	1	-	64	07001-00007	SCREW	1	1
21	07500-00317	● INSERT RETAINER	1	-	65	07500-00216	GASKET	1	1
22	07001-00114	● SCREW	2	4	66	07003-00033	SEAL	4	4
23	07003-00033	● SEAL	2	4	67	07001-00059	SCREW	4	1
24	07500-01800	CYLINDER HEAD ASSY	1	-	68	07500-00201	AIR CYLINDER	1	-
25	07003-00120	● 'O' RING	1	1	69	07500-00203	PISTON BUFFER	1	1
26	07500-04200	● RESERVOIR VALVE ASSY	1	-	70	07004-00038	CIRCLIP	1	1
27	07003-00032	● 'O' RING	1	1	71	07003-00082	'O' RING	1	1
28	07500-06500	● RESERVOIR PISTON ASSY	1	-	72	07003-00025	'O' RING	1	1
29	07220-02103	● SPRING	1	1	73	07001-00116	SCREW	12	3
30	07500-00403	● VALVE 'O' RING WASHER	4	-	74	07500-00211	HEAD GASKET	1	1
31	07500-00407	● REAR VALVE SEAT	1	-	75	07500-00205	ANTI-EXTRUSION RING	1	2
32	07500-00418	● SPRING	1	1	76	07003-00084	'O' RING	1	1
33	07001-00118	● SCREW	1	1	77	07003-00090	SPIRAL BACK UP RING	2	2
34	07003-00103	● 'O' RING	4	4	78	07003-00089	'H' RING SEAL	1	1
35	07500-00401	● VALVE STEM	1	-	79	07500-00206	VALVE OPERATING ROD	1	1
36	07500-00404	● 'O' RING SPACER	2	-	80	07003-00106	WIPER RING	1	1
37	07003-00086	● 'O' RING	2	2	81	07500-00212	NOSE RETAINING NUT	1	1
38	07500-00406	● FRONT VALVE SEAT	1	-	82	07500-01902	FOAM SILENCER	1	-
39	07500-00402	● VALVE STEM EXTENSION	1	-	83	07500-00207	L.H. COVER	1	-
40	07500-01300	AIR PISTON ASSY	1	-	84	07001-00117	SCREW	6	2
41	07003-00109	● SEAL	1	5	85	07002-00033	SPRING WASHER	6	2
42	07003-00006	● SPIRAL BACK UP RING	1	1	86	07500-00210	R.H. COVER	1	-
43	07500-00704	● RETAINING PLATE	1	-	87	07500-01903	FOAM SILENCER	1	-
44	07500-00703	● AIR BLEED INSERT	1	-					

# PRIMING

Priming is ALWAYS necessary after the tool has been dismantled and prior to operating. It may also be necessary to restore the full stroke after considerable use, when the stroke may be reduced and fasteners are not fully placed by one operation of the trigger.

## OIL DETAILS

The recommended oil for priming is Hyspin VG32 available in 0.5l (part number 07992-00002) or one gallon containers (part number 07992-00006). Please find specific table and safety data below.

H Y S P I N V G 3 2 O I L S A F E T Y D A T A			
<b>FIRST AID</b> SKIN: Wash thoroughly with soap and water as soon as possible. Casual contact requires no immediate attention. Short term contact requires no immediate attention. INGESTION: Seek medical attention immediately. DO NOT induce vomiting. EYES: Irrigate immediately with water for several minutes. Although NOT a primary irritant, minor irritation may occur following contact. <b>FIRE</b> Suitable extinguishing media: CO <sub>2</sub> , dry powder, foam or water fog. DO NOT use water jets.		<b>ENVIRONMENT</b> WASTE DISPOSAL: Through authorised contractor to a licensed site. May be incinerated. Used product may be sent for reclamation. SPILLAGE: Prevent entry into drains, sewers and water courses. Soak up with absorbent material. <b>HANDLING</b> Wear eye protection, impervious gloves (e.g. of PVC) and a plastic apron. Use in well ventilated area. <b>STORAGE</b> No special precautions.	
PROPERTIES	RESULT		PROPERTIES
ISO oil type		HL	Foaming tendency/stability
ISO viscosity grade		32	ml @ 24°C
Kinematic viscosity			ml @ 93.5°C
	cS @ 40°C	32	ml @ 24°C after test @ 93.5°C
	@ 100°C	5.3	Air release value minutes to
Relative density	at 20°C	0.875	0.2% air content @ 50°C
Viscosity Index		95	Seal compatibility index
Pour point	°C	- 30	Water separation time
Open Flash point	°C	232	in minutes to 40-40-0 @54°C
Neutralisation value mg KOH/g		1.5	@83°C
			Trace/Nil
			20/Nil
			Trace/Nil
			4
			10
			15
			15

## PROCEDURE

Item numbers in bold refer to the general assembly and parts list pages 16 and 17.

### IMPORTANT

**DO NOT OPERATE THE TRIGGER WHILE THE BLEED SCREW IS REMOVED.**

All operations should be carried out on a clean bench, with clean hands in a clean area.

Ensure that the priming pump is free from foreign matter

and that the oil is perfectly clean and free from air bubbles.

Care **MUST** be taken at all times, to ensure that no foreign matter enters the tool, or serious damage may result.

After dismantling the tool, it is necessary to prime the tool in the following manner.

- Hold the trigger in and disconnect the tool from the air supply.
- Remove the rear bleed screw and washer (item **84** and **85** page 16).
- Offer priming pump to priming nipple and pump until non-aerated oil issues from the rear bleed hole. Replace and tighten rear bleed screw **84**.

- 
- Top up priming pump and operate until resistance is felt. Remove priming pump.
  - Tighten front bleed screw and connect tool to air supply.
  - Slacken front bleed screw and depress trigger. Tighten front bleed screw and release trigger. Ensure that the reservoir is kept full.
  - Repeat until non-aerated oil flows from the front bleed hole. Provision should be made to catch expelled oil.
  - Tighten front bleed screw.
  - Cycle tool, ensuring reservoir is kept full, until full stroke 12.7mm (0.5") is achieved.
  - If full stroke is not achieved, repeat process.
- 
- Connect priming pump to priming nipple (item 58 page 16).
  - Operate priming pump until resistance is felt. Remove priming pump.
  - Cycle tool, ensuring that reservoir is kept full, until full stroke 12.7 mm (0.5") is achieved.
  - If tool fails to attain full stroke or will not place bolts after this procedure, use the following procedure.

# FAULT DIAGNOSIS

## FAULT DIAGNOSIS TABLE

SYMPTOM	POSSIBLE CAUSE	REMEDY
Short stroke or incomplete return	→ Air leak	→ Tighten joints or replace components
	→ Broken gasket	→ Replace gasket
	→ Oil level in tool low or air in oil	→ Re-prime tool (see page 18)
Tool fails to grip Lockbolt	→ Incorrect nose assembly fitted	→ Change to correct nose assembly
	→ Broken jaws in nose assembly	→ Replace
	→ Worn or dirty jaws	→ Clean or renew as necessary
Tool fails to break Lockbolt	→ Insufficient air pressure	→ Adjust air pressure
	→ Incorrect length of bolt	→ Change to correct length bolt
	→ Tool requires priming	→ Reprime tool (see page 18)
	→ Tool exhaust silencer dirty	→ Clean silencer
	→ Control valve dirty	→ Clean valve
Tool fails to swage collar	→ Insufficient air pressure	→ Adjust air pressure
	→ Worn anvils	→ Replace
	→ Tool requires priming	→ Reprime tool (see page 18)
	→ Swaging anvil cracked	→ Replace
	→ Incorrect length of bolt	→ Change to correct length bolt
Tool slows and fails to actuate	→ Exhaust silencer dirty	→ Clean silencer
	→ Air in oil	→ Reprime tool (see page 18)



**Engineered Fastening and Assembly Systems****Declaration of Conformity**

We, *Avdel Systems Limited, Mundells, Welwyn Garden City, Herts, AL7 1EZ*

declare under our sole responsibility that the product

*type 07500*

*Serial N°*

to which this declaration relates is in conformity with the following standards or other formative documents

EN292 part 1 and part 2

ISO 8662 part 1

ISO 3744

ISO PREN792 part 14

following the provisions of the Machine Directive 89/392/EEC  
(as amended by Directive 91/368/EEC, 93/44/EEC) and 93/68/EEC



Welwyn Garden City - date of issue

A R Dear - Engineering Design Manager

**World Headquarters:**

**Avdel Systems Ltd**, Mundells, Welwyn Garden City, Herts AL7 1EZ United Kingdom - Tel: (01707) 328161 Fax: (01707) 338828

**Overseas Companies:**

Avdel Pty Ltd, 2263 Princes Highway, Mulgrave, Victoria 3170 **Australia**

Avdel GmbH, Industriestrasse B 13/Halle 2, A-2345 Brunn/Gebirge **Austria**

Avdel Inc, 2696 Slough Street, Mississauga, Ontario L4T 1G3 **Canada**

Avdel SA, 33 bis, rue des Ardennes, BP4 75921 Paris Cedex 19 **France**

Avdel GmbH, Postfach 1463, D-30835 Langenhagen **Germany**

Avdel SRL, Via Manin 350-21, 20099 Sesto Giovanni, Milan **Italy**

Avdel KK, Takahashi Building, 9-3, 5 Chome, Nishi-tenma, Kita-ku, Osaka 530 **Japan**

Avdel SA, Poligono Prado Overa, Edificio Prado Park, Autovia Madrid Toledo KM 7.8, Leganes 28916, Madrid **Spain**

Avdel Korea Ltd, Samyung Building, 1486-2 Socho Dong, Socho Ku, Seoul **S. Korea**

Ejot & Avdel System AB, PO BOX 9013 S-700 09 Örebro **Sweden**

Avdel Corporation, 50 Lackawanna Avenue, Parsippany, New Jersey 07054 **USA**