

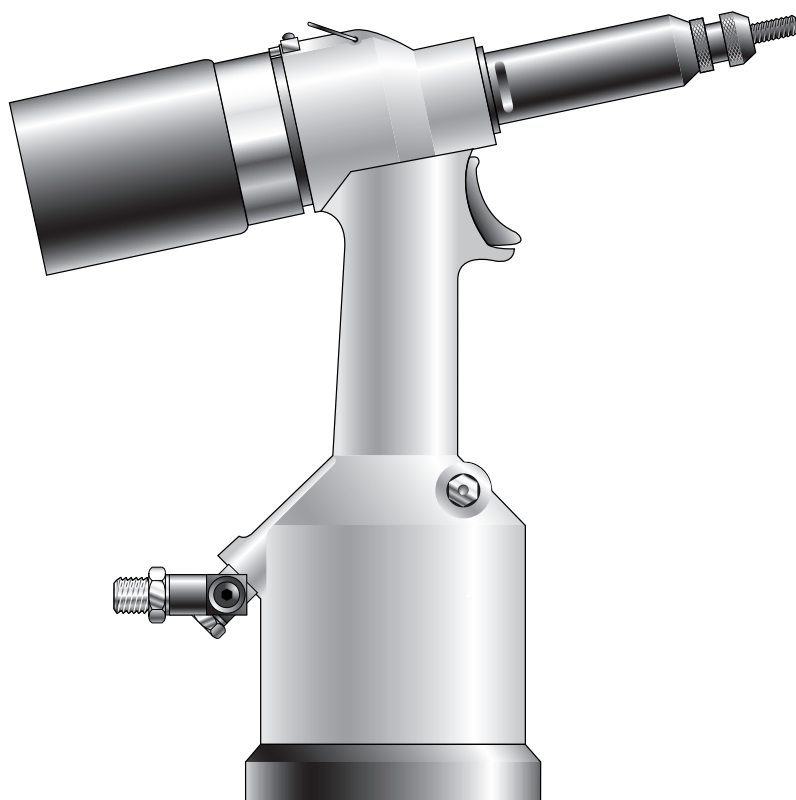

An Acument™ Global Technologies Company

Instruction Manual



74200

Threaded Insert Power Tool

Contents

Safety Rules	4
Tool Specifications	5
Intent of Use	6
Tool Dimensions	6
Putting into Service	
Air Supply	7
Stroke Adjustment	7
Operating Procedure	7
Nose Assemblies	
Fitting & Servicing Instructions	8
Selection	9
Servicing the Tool	
Daily / Weekly	10
Molykote 55M Safety Data	10
Service Kit	11
Maintenance	
Pneumatic Cylinder	12
Rod Guide	12
Trigger	12
Swivel Air Inlet	12
Differential Valve	13
Head Assembly	13
Rear Casing	13
Distributor	13
Hydraulic Piston & Air Motor Assembly	13
General Assembly of Base Tool	
General Assembly and Parts List	14-15
Priming	
Oil Details & Safety Data	16
Priming Procedure	16
Fault Diagnosis	
Symptom, Possible Cause & Remedy	17-18

LIMITED WARRANTY

Avdel makes the limited warranty that its products will be free of defects in workmanship and materials which occur under normal operating conditions. This Limited Warranty is contingent upon: (1) the product being installed, maintained and operated in accordance with product literature and instructions, and (2) confirmation by Avdel of such defect, upon inspection and testing. Avdel makes the foregoing limited warranty for a period of twelve (12) months following Avdel's delivery of the product to the direct purchaser from Avdel. In the event of any breach of the foregoing warranty, the sole remedy shall be to return the defective Goods for replacement or refund for the purchase price at Avdel's option. THE FOREGOING EXPRESS LIMITED WARRANTY AND REMEDY ARE EXCLUSIVE AND ARE IN LIEU OF ALL OTHER WARRANTIES AND REMEDIES. ANY IMPLIED WARRANTY AS TO QUALITY, FITNESS FOR PURPOSE, OR MERCHANTABILITY ARE HEREBY SPECIFICALLY DISCLAIMED AND EXCLUDED BY AVDEL.

Avdel UK Limited policy is one of continuous product development and improvement and we reserve the right to change the specification of any product without prior notice.

Safety Rules

This instruction manual must be read with particular attention to the following safety rules, by any person installing, operating, or servicing this tool.

- 1** Do not use outside the design intent.
- 2** Do not use equipment with this tool/machine other than that recommended and supplied by Avdel UK Limited.
- 3** Any modification undertaken by the customer to the tool/machine, nose assemblies, accessories or any equipment supplied by Avdel UK Limited or their representatives, shall be the customer's entire responsibility. Avdel UK Limited will be pleased to advise upon any proposed modification.
- 4** The tool/machine must be maintained in a safe working condition at all times and examined at regular intervals for damage and function by trained competent personnel. Any dismantling procedure shall be undertaken only by personnel trained in Avdel UK Limited procedures. Do not dismantle this tool/machine without prior reference to the maintenance instructions. Please contact Avdel UK Limited with your training requirements.
- 5** The tool/machine shall at all times be operated in accordance with relevant Health and Safety legislation. In the U.K. the "Health and Safety at Work etc. Act 1974" applies. Any question regarding the correct operation of the tool/machine and operator safety should be directed to Avdel UK Limited.
- 6** The precautions to be observed when using this tool/machine must be explained by the customer to all operators.
- 7** Always disconnect the airline from the tool/machine inlet before attempting to adjust, fit or remove a nose assembly.
- 8** Do not operate a tool/machine that is directed towards any person(s) or the operator.
- 9** Always adopt a firm footing or a stable position before operating the tool/machine.
- 10** Ensure that vent holes do not become blocked or covered and that hoses are always in good condition.
- 11** The operating pressure shall not exceed 7 bar (100 lbf/in²).
- 12** Do not operate the tool without full nose equipment, oil plug and oil bleed screw in place.
- 13** When using the tool, the wearing of safety glasses is required both by the operator and others in the vicinity to protect against pin ejection, should a fastener be placed 'in air'. We recommend wearing gloves if there are sharp edges or corners on the application.
- 14** Take care to avoid entanglement of loose clothes, ties, long hair, cleaning rags etc. in the moving parts of the tool which should be kept dry and clean for best possible grip.
- 15** When carrying the tool from place to place keep hands away from the trigger/lever to avoid inadvertent start up.
- 16** Excessive contact with hydraulic oil should be avoided. To minimise the possibility of rashes, care should be taken to wash thoroughly.

Specifications

Tool Specification

Air Pressure	Minimum - Maximum	5-7 bar (75-100 lbf/in ²)
Free Air Volume Required	@ 5 bar/75 lbf/in ²	8 litres (.28 ft ³)
Stroke	Maximum	7 mm (.276 in)
Motor Speed	Spin On	2000 rpm
	Spin Off	2000 rpm
Pull Force	@ 5 bar/75 lbf/in ²	19.1 kN (4300 lbf)
Cycle time	Approximately	2.5 seconds
Noise Level	Less than	75 dB(A)
Weight	Without nose equipment	2.2 kg (4.85 lb)
Vibration	Less than	2.5 m/s ² (8 ft/s ²)

Intent of Use

The hydro-pneumatic 74200 tool is designed to place Avdel® threaded inserts at high speed making it ideal for batch or flow-line assembly in a wide variety of applications throughout all industries.

A complete tool is made up of the base tool (part number 74200-12000) and the appropriate nose assembly for the insert, as described on page 9.

NOSE ASSEMBLIES MUST BE FITTED AS DESCRIBED ON PAGE 8.

Tool Dimensions

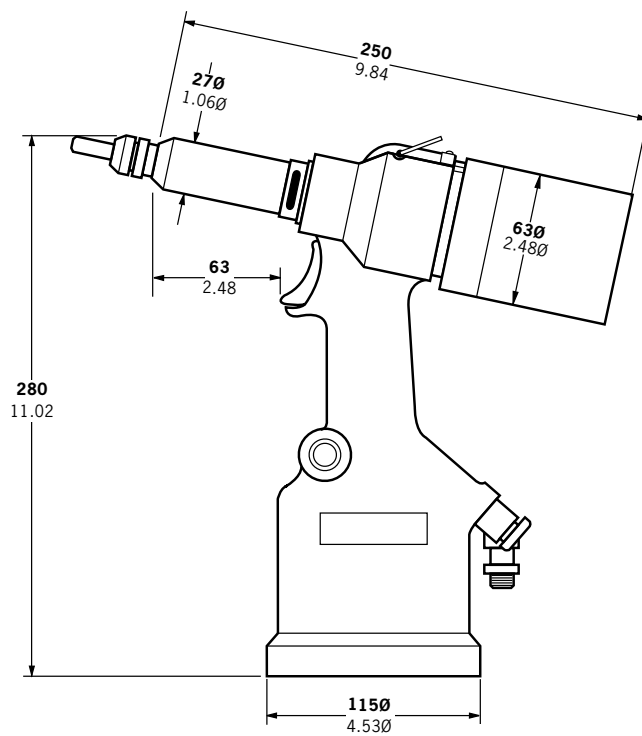

Dimensions shown in **bold** are millimetres. Other dimensions are in inches.

Putting into Service

Air Supply

All tools are operated with compressed air at an optimum pressure of 5.5 bar. We recommend the use of pressure regulators and automatic oiling/filtering systems on the main air supply. These should be fitted within 3 metres of the tool (see diagram below) to ensure maximum tool life and minimum tool maintenance.

Air supply hoses should have a minimum working effective pressure rating of 150% of the maximum pressure produced in the system or 10 bar, whichever is the highest. Air hoses should be oil resistant, have an abrasion resistant exterior and should be armoured where operating conditions may result in hoses being damaged. All air hoses MUST have a minimum bore diameter of 6.4 millimetres or 1/4 inch.

Read servicing daily details page 10.

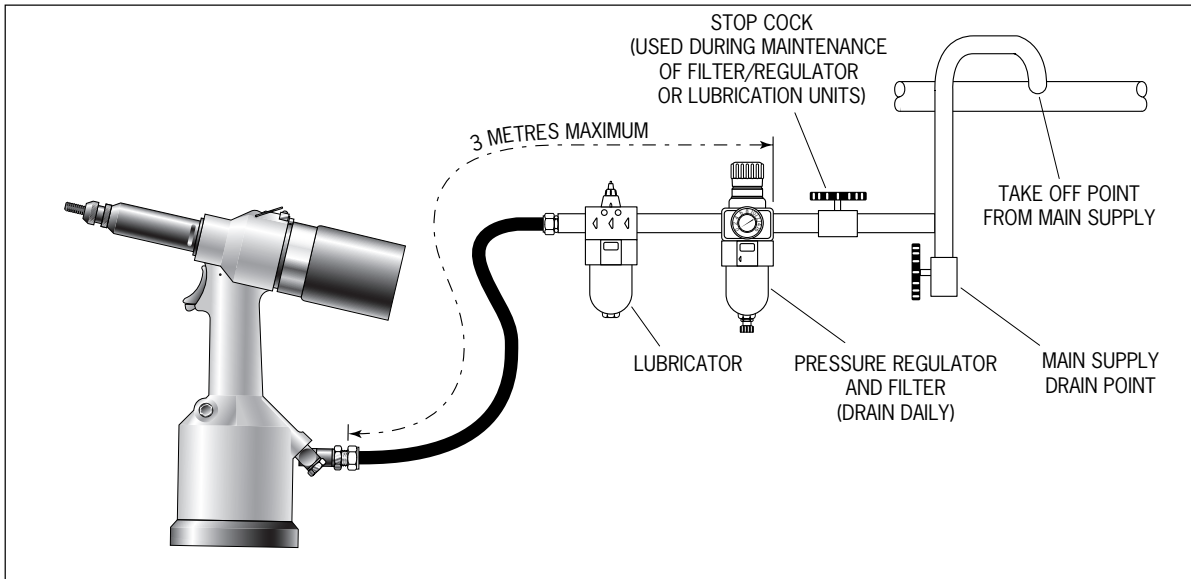

Stroke Adjustment

This adjustment is necessary to ensure optimum insert deformation. It is suggested, therefore, that a test plate with the same thickness and hole size as workpiece be used.

If deformation is insufficient, the insert will rotate inside the application. If deformation is excessive, thread distortion will occur and possibly drive screw fracture.

The stroke is adjusted by the amount the rear casing **86** is screwed in or out. To shorten stroke, screw in; to lengthen stroke, unscrew the rear casing but never more than 5 turns from the fully "IN" position unless dismantling the tool. Adjust until optimum deformation is obtained. Lock the stroke set finger **88** into the rear casing.

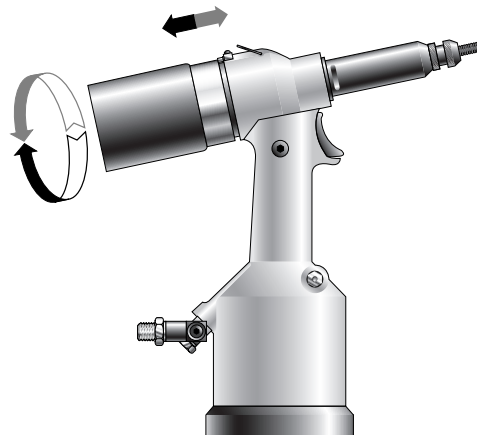

Operating Procedure

- Connect tool to air supply.
- Offer up insert, lip first to drive screw. A light pressure will start the motor and automatically thread the insert up against nose and stop.
- Insert fastener into application squarely.
- Fully depress trigger. This will both place insert into the application and reverse it off the drive screw.

Item numbers in **bold** refer to the General Assembly drawing and parts list (pages 14-15).

Nose Assemblies

It is essential that the correct nose assembly is fitted prior to operating the tool. By knowing the details of the fastener to be placed, you will be able to order a new complete nose assembly using the selection tables on page 9.

Fitting Instructions

IMPORTANT

The air supply must be disconnected when fitting or removing nose assemblies unless specifically instructed otherwise.

Item numbers in **bold** refer to illustration below:

- If still fitted remove the nose casing and the adaptor nut.
 - Insert drive shaft **4** into spindle.
 - Fit drive screw **3** onto drive shaft **4**.
 - Insert reducing sleeve **5** (if specified) into the adaptor nut.
 - Screw the adaptor nut onto the spindle.
 - Hold the spindle with a spanner* and tighten the adaptor nut clockwise.
 - While holding the adaptor nut with the spanner*, tighten the lock nut anti-clockwise.
 - Screw on the nose casing and nose tip **1** with the nose tip lock nut.
 - The reverse operation is carried out for equipment removal.
-
- With tool still disconnected from air supply, screw one insert onto drive screw manually - making sure the insert is flush with the end of drive screw.
 - Set nose tip in exact position and lock nose tip nut clockwise with a spanner*.
 - Remove the insert from drive screw.

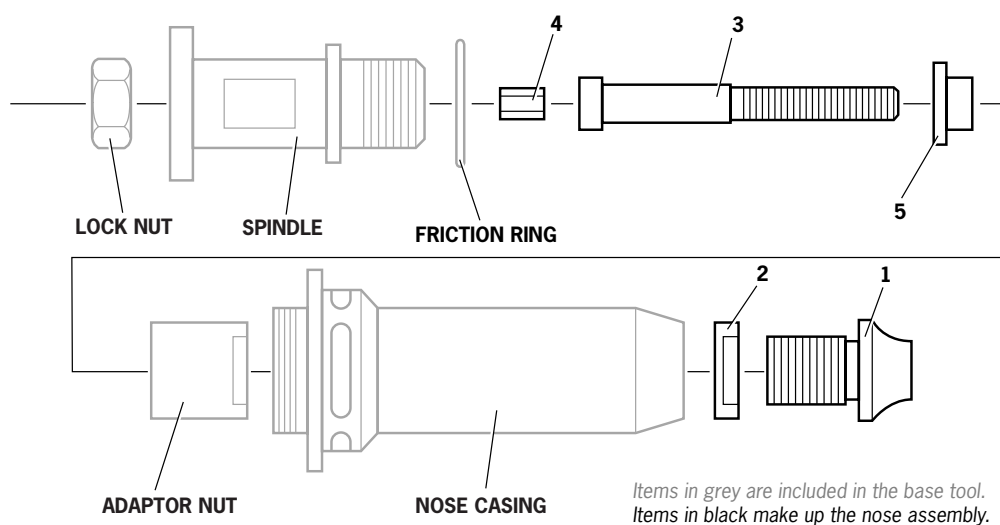

Servicing Instructions

Nose assemblies should be serviced at weekly intervals.

- Remove the complete nose assembly using the reverse procedure to the 'Fitting Instructions'.
- Any worn or damaged part should be replaced by a new part.
- Particularly check wear on drive screw.
- Assemble according to fitting instructions.

* Refers to items included in the 74200 service kit. For complete list see page 11.

Nose Assemblies

Nose tips vary in shape according to the insert type. Each nose assembly represents a unique assembly of components which can be ordered individually. All nose assemblies also include a nose tip locknut 2 (**part number 07555-00901**). Component numbers refer to the illustration on the opposite page. We recommend some stock as items will need regular replacement. Read the Nose Assemblies servicing instructions opposite carefully.

INSERT SIZE	COMPLETE TOOL	NOSE ASSEMBLY	1	3	4	5
LARGE FLANGE INSERTS (9698,FS58,9408,9418,9498) + STANDARD NUTSERT® (9500) + SQUARESERT® (GK08) + EUROSERT® (GJ08)						
M3	74200-00083	07555-09883	07555-00903	07555-09003	07555-01003	07555-09103
M4	74200-00084	07555-09884	07555-00904	07555-09004	07555-01004	07555-09104
M5*	74200-00085	07555-09885	07555-00905	07555-09005	07555-01005	07555-09105
M5**	74200-00485	07555-09185	07555-00915	07555-09005	07555-01005	07555-09105
M6	74200-00086	07555-09886	07555-00906	07555-09006	07555-01006	07555-09106
M8	74200-00088	07555-09888	07555-00908	07555-09008	07555-01008	07555-09108
M10	74200-00080	07555-09880	07555-00910	07555-09010	07555-01010	-
M12	74200-00082	74200-09882 †	07555-00912	07555-09012	07555-01012	-
4 UNC	74200-00054	07555-09854	07555-00854	07555-09054	07555-00754	07555-09154
6 UNC	74200-00056	07555-09856	07555-00856	07555-09056	07555-00756	07555-09156
8 UNC	74200-00058	07555-09858	07555-00858	07555-09058	07555-00758	07555-09158
10 UNC	74200-00050	07555-09850	07555-00850	07555-09050	07555-00750	07555-09150
1/4 UNC	74200-00048	07555-09848	07555-00848	07555-09048	07555-00748	07555-09148
5/16 UNC	74200-00040	07555-09840	07555-00840	07555-09040	07555-00740	07555-09140
3/8 UNC	74200-00042	07555-09842	07555-00842	07555-09042	07555-00742	-
10 UNF	74200-00070	07555-09870	07555-00850	07555-09070	07555-00750	07555-09150
1/4 UNF	74200-00068	07555-09868	07555-00848	07555-09068	07555-00748	07555-09148
5/16 UNF	74200-00060	07555-09860	07555-00840	07555-09060	07555-00740	07555-09140
3/8 UNF	74200-00062	07555-09862	07555-00842	07555-09062	07555-00742	-
3/16 BSW	74200-00016	07555-09816	07555-00850	07555-09016	07555-00750	07555-09150
1/4 BSW	74200-00018	07555-09818	07555-00848	07555-09018	07555-00748	07555-09148
5/16 BSW	74200-00010	07555-09810	07555-00840	07555-09019	07555-00740	07555-09140
THIN SHEET NUTSERT® (9468, FS38, 9650, 9488)						
M3	74200-00183	07555-09983	07555-00993	07555-09003	07555-01003	07555-09103
M4	74200-00184	07555-09984	07555-00994	07555-09004	07555-01004	07555-09104
M5	74200-00185	07555-09985	07555-00995	07555-09005	07555-01005	07555-09105
M6	74200-00186	07555-09986	07555-00996	07555-09006	07555-01006	07555-09106
M8	74200-00188	07555-09988	07555-00998	07555-09008	07555-01008	07555-09108
M10	74200-00180	07555-09980	07555-00999	07555-09010	07555-01010	-
M12	74200-00182	74200-09982 †	07555-00992	07555-09012	07555-01012	-
4 UNC	74200-00154	07555-09954	07555-00954	07555-09054	07555-00754	07555-09154
6 UNC	74200-00156	07555-09956	07555-00956	07555-09056	07555-00756	07555-09156
8 UNC	74200-00158	07555-09958	07555-00958	07555-09058	07555-00758	07555-09158
10 UNC	74200-00150	07555-09950	07555-00950	07555-09050	07555-00750	07555-09150
1/4 UNC	74200-00148	07555-09948	07555-00948	07555-09048	07555-00748	07555-09148
5/16 UNC	74200-00140	07555-09940	07555-00940	07555-09040	07555-00740	07555-09140
10 UNF	74200-00170	07555-09970	07555-00950	07555-09070	07555-00750	07555-09150
1/4 UNF	74200-00168	07555-09968	07555-00948	07555-09068	07555-00748	07555-09148
5/16 UNF	74200-00160	07555-09960	07555-00940	07555-09060	07555-00740	07555-09140
3/16 BSW	74200-00116	07555-09916	07555-00950	07555-09016	07555-00750	07555-09150
1/4 BSW	74200-00118	07555-09918	07555-00948	07555-09018	07555-00748	07555-09148
OBA	74200-00130	07555-09930	07555-00996	07555-09030	07555-01006	07555-09106
2BA	74200-00132	07555-09932	07555-00950	07555-09032	07555-00750	07555-09150
4BA	74200-00134	07555-09934	07555-00934	07555-09034	07555-00756	07555-09134
SUPERSERT® - OPEN AND CLOSED END (FB)						
M3	74200-00283	07555-09583	07555-07103	07555-09003	07555-01003	07555-09103
M4	74200-00284	07555-09584	07555-07104	07555-09004	07555-01004	07555-09104
M5	74200-00285	07555-09585	07555-07105	07555-09005	07555-01005	07555-09105
M6	74200-00286	07555-09586	07555-07106	07555-09006	07555-01006	07555-09106
M8	74200-00288	07555-09588	07555-07108	07555-09008	07555-01008	07555-09108
8 UNC	74200-00258	07555-09558	07555-07158	07555-09058	07555-00758	07555-09158
10 UNC	74200-00250	07555-09550	07555-07150	07555-09050	07555-00750	07555-09150
1/4 UNC	74200-00248	07555-09548	07555-07148	07555-09048	07555-00748	07555-09148
8 UNF	74200-00278	07555-09578	07555-07158	07555-09078	07555-00758	07555-09158
10 UNF	74200-00270	07555-09570	07555-07150	07555-09070	07555-00750	07555-09150
1/4 UNF	74200-00268	07555-09568	07555-07148	07555-09068	07555-00748	07555-09148
HEXSERT® (9688)						
M3	74200-00683	07555-09283	07555-08103	07555-09003	07555-01003	07555-09103
M4	74200-00684	07555-09284	07555-08104	07555-09004	07555-01004	07555-09104
M5	74200-00685	07555-09285	07555-08105	07555-09005	07555-01005	07555-09105
M6	74200-00686	07555-09286	07555-08106	07555-09006	07555-01006	07555-09106
M8	74200-00688	07555-09288	07555-00998	07555-09008	07555-01008	07555-09108

- Places all inserts listed in this section except M5 large flange Thin Sheet Nutsert®
- Places M5 large flange Thin Sheet Nutsert® 09698-00516 ONLY
- † These nose assemblies include an adaptor nut part number 74200-12119 to replace the one on the tool.

Servicing the Tool

Regular servicing should be carried out and a comprehensive inspection performed annually or every 500,000 cycles, whichever is sooner.

I M P O R T A N T

**The employer is responsible for ensuring that tool maintenance instructions are given to the appropriate personnel.
The operator should not be involved in maintenance or repair of the tool unless properly trained.**

Daily

- Daily, before use or when first putting the tool into service, pour a few drops of clean, light lubricating oil into the air inlet of the tool if no lubricator is fitted on air supply. If the tool is in continuous use, the air hose should be disconnected from the main air supply and the tool lubricated every two to three hours.
- Check for air leaks. If damaged, hoses and couplings should be replaced by new items.
- If there is no filter on the pressure regulator, bleed the air line to clear it of accumulated dirt or water before connecting air hose to tool.
- Check that the nose assembly is correct.
- Check the stroke of the tool is adequate to place selected insert. (See stroke adjustment page 7).
- Inspect the drive screw in the nose assembly for wear or damage. If any, renew.

Weekly

- Check for oil leaks and air leaks on air supply hose and fittings.

Molykote 55m Safety Data

Grease can be ordered as a single item, the part number is shown in the service kit page 11.

First Aid

SKIN: Wipe off and wash with soap and water.

INGESTION: No adverse effects are normally expected.
Treat symptomatically.

EYES: Irritant but not harmful. Irrigate with water and seek medical attention.

Environment

Scrape up for incinerating or disposal on approved site.

Fire

FLASH POINT: 101°C
Not classified as flammable.
Suitable extinguishing media: Carbon dioxide, foam, dry powder or fine water spray.

Handling

Plastic or rubber gloves should be worn.

Storage

Away from heat and oxidising agent.

Servicing the Tool

Service Kit

For all servicing we recommend the use of the service kit (part number 74200-99990) supplied in its own plastic case.

SERVICE KIT		
ITEM PART N°	DESCRIPTION	N° OFF
07900-00618	PUSHER	1
07900-00619	GUIDE BUSH	1
07900-00478	Ø 3mm PIN PUNCH	1
07900-00624	Ø 4mm PIN PUNCH	1
07900-00157	INTERNAL CIRCLIP PLIERS	1
07900-00161	EXTERNAL CIRCLIP PLIERS	1
07900-00625	SOFT MALLET	1
07900-00623	25mm SOCKET	1
07900-00006	SPATULA	1
07900-00434	32mm SPANNER	1
07900-00621	28mm SPANNER	1
07900-00637	17mm SPANNER	1
07900-00643	PUSHER KNOB	1

SERVICE KIT (Continued)		
ITEM PART N°	DESCRIPTION	N° OFF
07900-00393	14mm/15mm SPANNER	1
07900-00409	12mm/13mm SPANNER	1
07900-00626	11mm SPANNER	1
07900-00469	2.5mm ALLEN KEY	1
07900-00351	3mm ALLEN KEY	1
07900-00224	4mm ALLEN KEY	1
07900-00225	5mm ALLEN KEY	1
07900-00620	12mm ALLEN KEY	1
07900-00456	T BAR	1
07992-00075	MOLYKOTE 55M (100 gm TUBE)	1
07900-00627	PLASTIC CASE	1
07900-00632	17mm/19mm SPANNER	2

Maintenance

Every 500,000 cycles the tool should be completely dismantled and components replaced where worn, damaged or when recommended. All 'O' rings and seals should be replaced with new ones and lubricated with Molykote 55M grease before assembling.

IMPORTANT

Safety Instructions appear on page 4.
The employer is responsible for ensuring that tool maintenance instructions are given to the appropriate personnel.
The operator should not be involved in maintenance or repair of the tool unless properly trained.

The airline must be disconnected before any servicing or dismantling is attempted unless specifically instructed otherwise.

It is recommended that any dismantling operation be carried out in clean conditions.
Before proceeding with dismantling, empty the oil from the tool. Remove oil plug **42**, oil seal washer **43**, bleed screw **48** and bleed screw washer **49** from the handle assembly and drain the oil into a suitable container.

Prior to dismantling the tool it is necessary to remove the nose assembly. For simple removal instructions see the nose assemblies section, pages 8-9.

For total tool servicing we advise that you proceed with dismantling of sub-assemblies in the order shown below.

Pneumatic Cylinder

- Remove rubber base **2**.
- Place tool, base uppermost in vice fitted with soft jaws.
- Using a spanner*, unscrew end plug **3**. Pneumatic piston **9** should move upward under spring **11** pressure (it may be necessary to exert hand pressure to pneumatic piston **9**).
- Remove 'O' ring **4**.
- Withdraw pneumatic piston **9**.
- Remove lip seal **8** and 'O' ring **36**.
- Hold piston rod **10** in soft vice jaws to avoid scratching rod diameter.
- Separate piston rod **10** from pneumatic piston **9** by unscrewing piston rod fastening bolt **5** using a spanner*.
- Inspect air tube **12** for damage or distortion. (Air tube is screwed internally into handle and set in position with Loctite 222) If it is necessary to remove air tube, the base of the air tube will require warming to a temperature of 100o C to soften the Loctite adhesive. The air tube **12** can then be unscrewed from the handle using an Allen key*.
- Check spring **11** is not distorted or damaged.
- Assembly is in reverse order to dismantling.

Rod Guide

- With tool in upside down position in vice, unscrew rod guide **15** using a spanner* and T-bar*.
- Withdraw rod guide **15**.
- Unscrew locknut **13** using an Allen key*, remove seal **14** and 'O' ring **98**.
- Remove 'O' ring **16**.
- Assembly is in reverse order to dismantling.

Trigger

- With tool held in vice, remove pin **26** using a pin punch*.
- Remove trigger **25**, pin **22**, roller **23** and push wedge **24**.
- Gently push on the head of trigger rod **20** and, remove together with 'O' rings **7** and **21**, guide **19**, lip seal **18** and plug **17**.
- Assembly is in reverse order to dismantling. Ensure lip of lip seal **18** is towards head of tool.

Swivel Air Inlet (74200-12700)

- Using an Allen key* remove screw **40** and washer **39**.
- Remove swivelling inlet **38**.
- Unscrew double male connector **41** from swivelling inlet **38** and remove nylon washer **33**.
- Using a spanner*, remove drilled bolt **37**.
- Remove two nylon washers **33** and air inlet block **35**.
- Remove circlip **97** from double male connector **41** using circlip pliers and withdraw sintered filter **96**.
- Assemble in reverse order of dismantling.

* Refers to items included in the 74200 service kit. For complete list see page 11.
Item numbers in **bold** refer to the General Assembly drawing and parts list (pages 14-15).

Maintenance

Differential Valve

- Using special flat spanner* unscrew valve locking plug **27**, withdraw and remove spring **104** and 'O' ring **29**.
- Remove silencer **34** using a spanner* and remove nylon washer **33**.
- Push valve piston **28** out from its housing together with 'O' rings **30**, **31** & **32**.
- Check spring **104** for distortion and renew if required.
- Assemble in reverse order of dismantling.

Head Assembly

- Remove nose equipment prior to commencing dismantling.
- Using spanners* remove spindle **44** and locknut **45**.
- Remove return spring locknut **46** using a spanner*.
- Remove return spring **47**, washer **99** and locking ring **90**.
- Check return spring **47** for distortion and renew if required.
- Assemble in reverse order of dismantling.

Rear Casing

- Using an Allen key* remove screw **40** from stroke set finger **88** and lift off bridge washer **95**.
- Disengage stroke set finger **88** by pushing it back against spring **89**.
- Unscrew rear casing **86**.
- Remove rear casing rubber band **87** if necessary.
- Extract circlip **84** using circlip pliers* and remove sintered silencer **85**.
- Complete assembly in reverse order of dismantling. Locate pawl **102** in head before screwing on rear casing **86**.

Distributor

- Using an Allen key* remove two screws **40**.
- Withdraw distributor **83** together with air motor end plug **81** and 'O' rings **82** & **31** taking care not to drop ball **79** and push rod **78**.
- Using an Allen key* remove four countersunk socket head screws **58** and withdraw stroke stop **57**.
- Pull out two air supply tubes **59** and four 'O' rings **60**.
- Assemble in reverse order of dismantling.

Hydraulic Piston & Air Motor Assembly (74200-12610)

- Wrap adhesive tape around hydraulic piston **54** thread and move assembly backwards slowly and firmly. Using circlip pliers* remove circlip **52** and front seal **51**.
- Remove 'O' rings **76** and **77**.
- Using two spanners* separate the hydraulic piston **54** from air motor casing **75**. Shim adjustment ring **55**, movement pivot **56** and 'O' ring **101** will come out with hydraulic piston **54**.
- Remove air motor assembly out of air motor casing **75**, remove circlip **61** using circlip pliers*, then tap air motor casing **75** on bench to free components.
- Parts **62** to **74** can be pulled out as an assembly, taking care not to drop pin **74**.
- Remove bearing **62**, planet gear spindle **63**, three planets **64**, planet gear **65** and spacer **66**.
- Using a soft mallet tap splined head of rotor **70**.
- Bearing **67** and front end plate **68** will come out with stator **69** and five rotor blades **71**. (rotor **70** remains in hand).
- Place rear end plate **72** in vice with soft jaws.
- Using a pin punch* tap centre of rotor **70** to remove bearing **73**. (turn rotor **70** upside down and bearing **73** will come out).
- When assembling air motor, rear side of rotor **70** must just touch rear end plate **72** without any axial gap, (any existing gap will disappear when bearing **73** is fully located).
- When inserting air motor into air motor casing **75** carefully align parts so that pin **74** locates in centre hole between spin on/off ports of air motor casing **75** and rear end plate **72**.
- When assembling hydraulic piston **54** onto air motor assembly, tighten parts by hand and blow air into one of the outer ports of air motor casing **75**, checking to see air motor rotates freely.
- When assembling front seal **51** ensure larger diameter faces rear of tool.
- Complete assembly in reverse order to dismantling.

IMPORTANT

**Check the tool against daily and weekly servicing.
Priming is ALWAYS necessary after the tool has been dismantled and prior to operating**

* Refers to items included in the 74200 service kit. For complete list see page 11.
Item numbers in **bold** refer to the General Assembly drawing and parts list (pages 14-15).

General Assembly of Base Tool 74200-12000

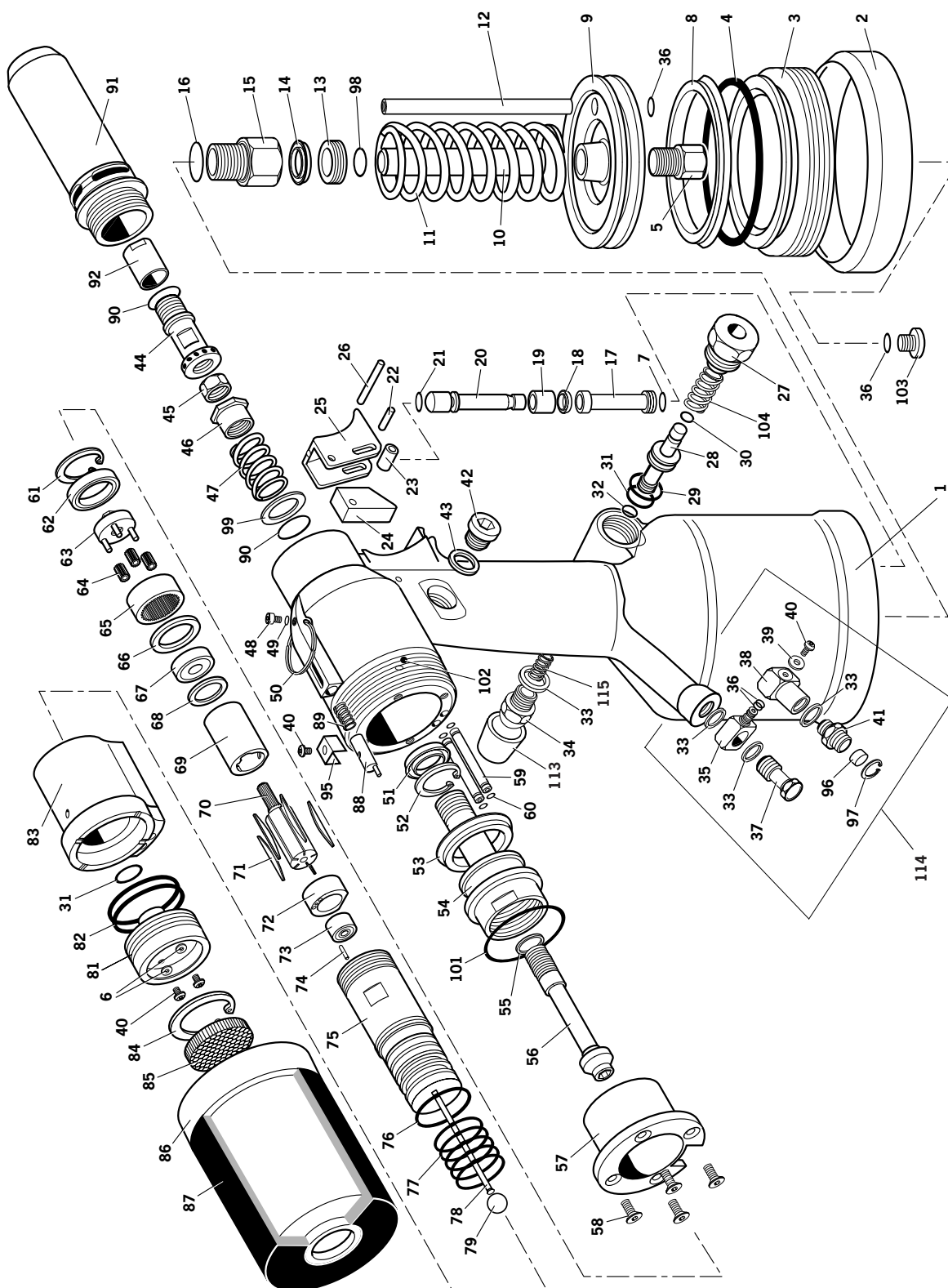

Parts List for 74200-12000

74200-12000 PARTS LIST

ITEM	PART N°	DESCRIPTION	QTY	REC. SPARES	ITEM	PART N°	DESCRIPTION	QTY	REC. SPARES	ITEM	PART N°	DESCRIPTION	QTY	REC. SPARES
01	74200-12001	HEAD & HANDLE	1	-	40	07001-00420	M4 BUTTON SOCKET HD SCREW	4	4	79	74200-12079	BALL (RUBBER)	1	1
02	74200-12002	RUBBER BASE	1	1	41	74200-12041	1/4" DOUBLE MALE CONNECTOR	1	-	80	07007-01503	BOOKMARK LABEL	1	M
03	74200-12003	END PLUG (SCREWED)	1	-	42	07005-01274	OIL PLUG	1	1	81	74200-12081	AIR MOTOR END PLUG	1	-
04	74200-12004	'O' RING	1	1	43	74200-12043	OIL SEAL WASHER	1	1	82	74200-12082	'O' RING	2	2
05	74200-12005	PISTON ROD FASTENING BOLT	1	-	44	74200-12044	SPINDLE	1	1	83	74200-12083	DISTRIBUTOR	1	-
06	07002-00109	M4 SHAKEPROOF WASHER	2	-	45	07555-00803	LOCK NUT	1	1	84	74200-12084	CIRCLIP	1	1
07	07003-00027	'O' RING	2	2	46	74200-12046	RETURN SPRING LOCKNUT	1	1	85	74200-12085	SINTERED SILENCER	1	1
08	74200-12008	LIP SEAL (PNEUMATIC PISTON)	1	1	47	74200-12047	RETURN SPRING	1	1	86	74200-12086	REAR CASING	1	-
09	74200-12009	PNEUMATIC PISTON	1	-	48	07001-00329	M5 BLEED SCREW	1	1	87	74200-12087	REAR CASING RUBBER BAND	1	1
10	74200-12010	PISTON ROD (INTENSIFIER)	1	-	49	07003-00033	OIL SEAL BLEED WASHER	1	1	88	74200-12088	STROKE SET FINGER	1	1
11	07555-00205	SPRING	1	1	50	07265-03021	SUSPENSION RING	1	1	89	74200-12089	SPRING	1	1
12	74200-12012	AIR SUPPLY TUBE	1	1	51	07265-02004	FRONT SEAL	1	1	90	07003-00028	LOCKING RING	2	2
13	74200-12013	LOCK NUT	1	-	52	07004-00033	CIRCLIP	1	1	91	74200-12091	NOSE CASING	1	-
14	74200-12014	SEAL	1	1	53	74200-12053	SEAL	1	1	92	74200-12092	ADAPTOR NUT (UP TO M10)	1	1
15	74200-12015	ROD GUIDE	1	-	54	74200-12054	HYDRAULIC PISTON	1	-	93	74200-12093	COLOURED LABEL	1	M
16	07003-00100	'O' RING	1	1	55	74200-12055	SHIM ADJUSTMENT RING	1	1	94	07900-00354	TIE ON SAFETY LABEL	1	M
17	74200-12017	PLUG	1	-	56	74200-12056	MOVEMENT PIVOT	1	1	95	74200-12095	BRIDGE WASHER	1	1
18	74200-12018	LIP SEAL	1	1	57	74200-12057	STROKE STOP	1	-	96	74200-12096	SINTERED FILTERED	1	1
19	74200-12019	GUIDE	1	-	58	07001-00427	M5 CSK SOCKET HEAD SCREW	4	4	97	74200-12097	CIRCLIP	1	1
20	74200-12020	TRIGGER ROD	1	-	59	74200-12059	PNEU. MOTOR AIR SUPPLY TUBE	2	2	98	07003-00134	'O' RING	1	1
21	07003-00315	'O' RING	1	1	60	74200-12060	'O' RING	4	4	99	74200-12099	WASHER	1	1
22	74200-12022	PIN	1	1	61	74200-12061	CIRCLIP	1	1	100	07007-01526	'CE' LABEL (AVDEL ITALY)	1	M
23	74200-12023	ROLLER	1	1	62	74200-12062	BEARING	1	-	101	74200-12121	'O' RING	1	1
24	74200-12024	PUSH WEDGE	1	-	63	74200-12063	PLANET GEAR SPINDLE	1	-	102	74200-12122	PAWL (RUBBER)	1	1
25	74200-12025	TRIGGER	1	1	64	07555-09208	PLANET	3	-	103	74200-12103	PLUG	1	1
26	74200-12026	PIN	1	1	65	74200-12065	PLANET GEAR	1	-	104	74200-12104	SPRING	1	M
27	74200-12027	VALVE LOCKING PLUG	1	-	66	74200-12066	SPACER	1	1	105	07900-00614	TOOL MANUAL	2	M
28	74200-12028	VALVE PISTON	1	-	67	07555-09206	BEARING	1	-	106	07900-00632	17/19 MM THIN SPANNER	1	M
29	07003-00086	'O' RING	1	1	68	07555-09210	FRONT END PLATE	1	-	107	07900-00409	12/13 MM SPANNER	1	M
30	07003-00040	'O' RING	1	1	69	07555-09211	STATOR	1	-	108	07900-00224	4 MM ALLEN KEY	1	M
31	07003-00026	'O' RING	2	2	70	74200-12070	ROTOR	1	-	109	07900-00225	5 MM ALLEN KEY	1	M
32	07003-00046	'O' RING	1	1	71	07555-09213	ROTOR BLADE	5	5	110	07900-00624	4 MM Ø PIN PUNCH	1	M
33	74200-12033	1/8" NYLON WASHER	4	4	72	07555-09214	REAR END PLATE	1	-	111	07900-00637	SPECIAL 17 MM FLAT SPANNER	1	M
34	74200-12034	1/8" SILENCER	1	1	73	07555-09215	BEARING	1	-	112	07900-00469	2.5 MM ALLEN KEY	1	M
35	74200-12035	AIR INLET BLOCK	1	-	74	07555-09216	PIN	1	1	113	74200-12300	DEFLECTOR ASSEMBLY	1	M
36	07003-00029	'O' RING	4	4	75	74200-12075	AIR MOTOR CASING	1	-	114	74200-12300	INLET ASSEMBLY	1	-
37	74200-12037	DRILLED BOLT	1	-	76	07003-00305	'O' RING	1	1	115	07340-00401	SPRING	1	-
38	74200-12038	SWELLING INLET	1	-	77	07003-00306	'O' RING	5	5					
39	74200-12039	WASHER	1	1	78	74200-12078	PUSH ROD 80 mm LONG	1	1					

Priming

Priming is ALWAYS necessary after the tool has been dismantled and prior to operating. It may also be necessary to restore the full stroke after considerable use, when the stroke may be reduced and fasteners are not fully placed by one operation of the trigger.

Oil Details

The recommended oil for priming is Hyspin VG32 available in 0.5l (part number 07992-00002) or one gallon containers (part number 07992-00006). Please see safety data below.

Hyspin VG 32 Oil Safety Data

First Aid

SKIN:

Wash thoroughly with soap and water as soon as possible. Casual contact requires no immediate attention. Short term contact requires no immediate attention.

INGESTION:

Seek medical attention immediately. DO NOT induce vomiting.

EYES:

Irrigate immediately with water for several minutes. Although NOT a primary irritant, minor irritation may occur following contact.

Fire

Flash point 232°C. Not classified as flammable.

Suitable extinguishing media: CO₂, dry powder, foam or water fog. DO NOT use water jets.

Environment

WASTE DISPOSAL: Through authorised contractor to a licensed site. May be incinerated. Used product may be sent for reclamation.

SPILLAGE: Prevent entry into drains, sewers and water courses. Soak up with absorbent material.

Handling

Wear eye protection, impervious gloves (e.g. of PVC) and a plastic apron. Use in well ventilated area.

Storage

No special precautions.

Priming Procedure

IMPORTANT

**All operations should be carried out on a clean bench, with clean hands in a clean area.
Ensure that the oil is perfectly clean and free from air bubbles.
Care MUST be taken at all times, to ensure that no foreign matter enters the tool, or serious damage may result.
The tool must remain on its side throughout the priming sequence**

- Place tool on its side, oil plug **42** side up.
- Pull back stroke set finger **88** and unscrew rear casing **86** by a maximum of 5 turns from the fully 'IN' position.
- With an Allen key, unscrew oil plug **42** and remove with oil seal washer **43**.
- Fill tool with priming oil rocking gently to expel air.
- Replace oil seal washer **43** and oil plug **42** and tighten.
- You must now bleed the tool. This operation is to ensure air bubbles are eliminated from the oil circuit.
- Ensuring oil bleed screw **48** is fully tightened unscrew by ONE TURN only, using an Allen key. Connect the tool to the air supply and depress the trigger.
- Wait until oil appears all around oil bleed screw **48** then re-tighten. Wipe excess oil away.
- Release the trigger.
- Using an Allen Key open oil plug **42**.
- Top-up with priming oil to reset level. Replace oil seal washer **43** and oil plug **42** and fully tighten.
- It is necessary to fit the appropriate nose equipment and adjust the tool stroke prior to operating the tool.

Item numbers in **bold** refer to general assembly drawings and parts list (pages 14-15).

Fault Diagnosis

Symptom	Possible Cause	Remedy	Page Ref
Pneumatic motor runs slowly	Air leak from motor	Check for worn seals. Replace	13
	Low air pressure	Increase	7
	Air way blockage	Clear restriction in air supply	
	Worn drive screw	Replace	8
	Vanes jamming	Lubricate tool through air inlet	
Insert does not deform properly	Stroke incorrectly set	Adjust	7
	Air pressure outside the tolerance	Adjust	7
	Low oil level	Prime tool	16
	Insert out of grip	Check grip range of Insert	
Drivescrew turns independent of motor	Worn or damaged drive shaft	Replace	
	Worn or damaged drive screw	Replace	8
	Adaptor nut loose	Tighten	8
	Locking ring 90 missing	Fit new locking ring	13
Insert will not place onto drivescrew	Incorrect Insert thread size	Change to correct insert	
	Incorrect drive screw fitted	Change to correct drive screw	
	Worn or damaged drive screw	Replace	
	Nose equipment incorrectly assembled	Disconnect air supply, re-fit nose equipment carefully	8-9
Tool is jammed on placed insert	Excessive stroke/ Defective insert/ Worn or defective drive screw	DO NOT DEPRESS TRIGGER. Unlock stroke locking device and bring rear casing forward to zero stroke position. Depress trigger. Tool should spin off. Reset stroke. If not, disconnect air to tool. Insert a 4 mm Ø pin through nose casing slots into spindle 44 . Turn until drive screw leaves. Insert. Use new insert AND drive screw.	
Drive screw breaks	Stroke of tool excessive	Re-set stroke	
	Side load on drive screw	Hold tool square to application when placing Insert	

continued overleaf

Item numbers in **bold** refer to general assembly drawings and parts list (pages 14-15).

Other symptoms or failures should be reported to your local Avdel authorised distributor or repair centre.

Fault Diagnosis

Symptom	Possible Cause	Remedy	Page Ref
Tool does not spin on	Screw adaptor nut loose	Tighten	
	No air supply	Connect	7
	Insufficient gap between locknut 45 and spindle 44	Adjust to 1.5 mm gap to 2mm gap	13
	Push rod 78 too short	Replace	13
	Air motor jammed	Lubricate tool at air inlet. If insufficient dismantle and clean air motor thoroughly	
Trigger inoperative	Static friction	Depress trigger a few times	
	Low air pressure	Increase air pressure	
	Valve piston remains stuck	Depress trigger several times. Lubricate tool through air inlet. If unsuccessful, dismantle, clean and lubricate trigger elements	
Drivescrew does not return and/or keeps spinning off	Lip seal 18 is defective	Replace	12
Tool does not spin off	Adaptor nut 92 loose	Tighten	
	No air supply	Connect	
	Rear casing unscrewed by more than 5 turns	Set tool stroke	
	'O' ring 82 leaking air	Replace	13
	Distributor stuck	Lubricate	
	Air motor jammed	Lubricate tool at air inlet. If insufficient dismantle and clean air motor thoroughly	

Item numbers in **bold** refer to general assembly drawings and parts list (pages 14-15).

Other symptoms or failures should be reported to your local Avdel authorised distributor or repair centre.

Declaration of Conformity

We, Avdel UK Limited, Watchmead Industrial Estate, Welwyn Garden City, Herts, AL7 1LY
declare under our sole responsibility that the product:

Model Type 74200

Serial No.

to which this declaration relates is in conformity with the following standards:

EN ISO 12100 - parts 1 & 2

BS EN ISO 8662 - part 6

BS EN ISO 3744

ISO EN 792 - part 13 - 2000

BS EN ISO 11202

BS EN 982

BS EN 983

following the provisions of the Machine Directive 89/392/EC
(as amended by Directive 91/368/EC, 93/44/EC and 93/68/EC)
and superseded by 98/37/EC



M. Delle Fave - Quality Manager

Date of issue



**This box contains a power tool which is in
conformity with Machines Directive
89/392/EC. The 'Declaration of Conformity'
is contained within.**



An Acument™ Global Technologies Company

AUSTRALIA

Acument Australia Pty Ltd.
891 Wellington Road
Rowville, Victoria 3178
Tel: +61 3 9765 6400
Fax: +61 3 9765 6445
Email: info@acument.com.au

CANADA

**Avdel Canada, a Division of Acument
Canada Limited**
87 Disco Road
Rexdale
Ontario M9W 1M3
Tel: +1 416 679 0622
Fax: +1 416 679 0678
Email: infoAvdel-Canada@acument.com

CHINA

Acument China Ltd.
RM 1708, 17/F., Nanyang Plaza,
57 Hung To Rd., Kwun Tong
Hong Kong
Tel: +852 2950 0631
Fax: +852 2950 0022
Email: info@acument.com.hk

FRANCE

Avdel France S.A.S.
33 bis, rue des Ardennes
BP4
75921 Paris Cedex 19
Tel: +33 (0) 1 4040 8000
Fax: +33 (0) 1 4208 2450
Email: AvdelFrance@acument.com

GERMANY

Avdel Deutschland GmbH
Klusriede 24
30851 Langenhagen
Tel: +49 (0) 511 7288 0
Fax: +49 (0) 511 7288 133
Email: AvdelDeutschland@acument.com

ITALY

Avdel Italia S.r.l.
Viale Lombardia 51/53
20047 Brugherio (MI)
Tel: +39 039 289911
Fax: +39 039 2873079
Email: vendite@acument.com

JAPAN

Acument Japan Kabushiki Kaisha
Center Minami SKY,
3-1 Chigasaki-Chuo, Tsuzuki-ku,
Yokohama-city, Kanagawa Prefecture
Japan 224-0032
Tel: +81 45 947 1200
Fax: +81 45 947 1205
Email: info@acument.com.jp

SINGAPORE

Acument Asia Pacific (Pte) Ltd.
#05-03/06 Techlink
31 Kaki Bukit Road 3
Singapore, 417818
Tel: +65 6840 7431
Fax: +65 6840 7409
Email: Tlim@acument.com

SOUTH KOREA

Acument Korea Ltd.
212-4, Suyang-Ri,
Silchon-Eup, Kwangju-City,
Kyunggi-Do, Korea, 464-874
Tel: +82 31 798 6340
Fax: +82 31 798 6342
Email: info@acumentkorea.com

SPAIN

Avdel Spain S.A.
C/ Puerto de la Morcuera, 14
Poligono Industrial Prado Overa
Ctra. de Toledo, km 7,8
28919 Leganés (Madrid)
Tel: +34 (0) 91 3416767
Fax: +34 (0) 91 3416740
Email: ventas@acument.com

UNITED KINGDOM

Avdel UK Limited
Pacific House
2 Swiftfields
Watchmead Industrial Estate
Welwyn Garden City
Hertfordshire
AL7 1LY
Tel: +44 (0) 1707 292000
Fax: +44 (0) 1707 292199
Email: enquiries@acument.com

USA

Avdel USA LLC
614 NC Highway 200 South
Stanfield,
North Carolina 28163
Tel: +1 704 888-7100
Fax: +1 704 888-0258
Email: infoAvdel-USA@acument.com

© Avdel UK Limited 2007

Manual No.	Issue	Change Note No.	Date
07900-00614	AA		11-01
	B	07/044	01-07
	B2	07/103	03-07