

Hemlok®

Structural breakstem fasteners with exceptional shear and tensile strength and a large blind side bearing area against the rear sheet.



Key features and benefits

- All steel version provides exceptional shear and tensile strength
- Large blind side bearing area spreads the tail bearing load/ clamp load on the rear sheet reducing creep e.g. in plastic material
- Interference lock formed by a splined stem provides strong, vibration resistant joints
- No damage, electrical problems or rattling caused by loose stems

Specifications

Sizes:

6.4 mm (1/4")

Materials:

Aluminium alloy and steel

Headform:

Protruding

Typical placing sequence

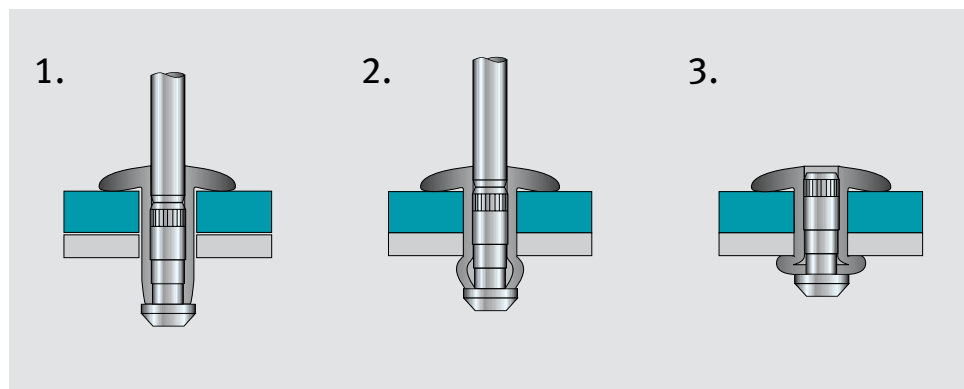

Please visit our website www.avdel-global.com for fastener placing animations and technical data.

Assembly applications

- Automotive
- Warehouse racking
- Ladders

Scaffold tower



Step ladder



Car seat base



Vehicle mud flaps

