

Bulbex[®]

Aluminium alloy breakstem fasteners with a split tail formation providing a very large blind side bearing area against the rear sheet. Ideal for use in thin sheet or low strength material.



Key features and benefits

- Split tail formation provides a very large blind side bearing area against the rear sheet
- Spreads the tail bearing load/clamp load on the rear sheet providing high resistance to pull-out loads
- Multi-grip capability accommodates wide variations in material thickness
- Retained stem avoids damage, electrical problems or rattling caused by loose stems

Specifications

Sizes:

4.0 mm and 4.8 mm
(5/32" and 3/16")

Material:

Aluminium alloy

Headform:

Dome

Typical placing sequence

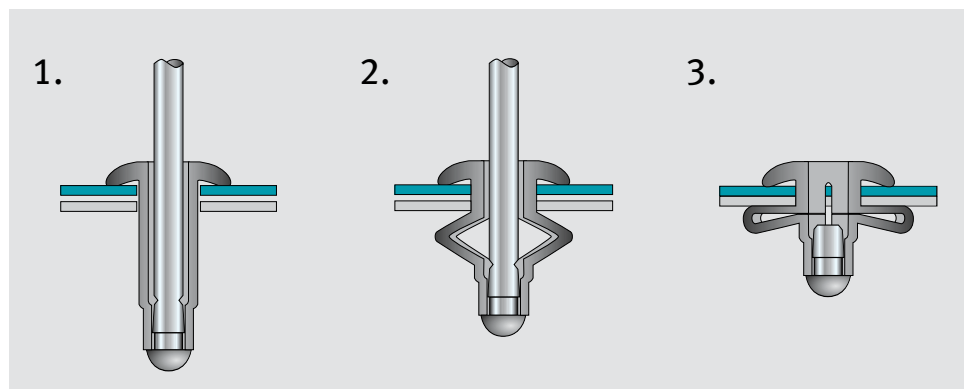

Please visit our website www.avdel-global.com for fastener placing animations and technical data.

Assembly applications

- Automotive
- Caravans/RV
- Mobile homes
- Domestic appliances
- Plastic components

Caravans/RV



Mobile homes



Speaker systems

