

Hydro Pneumatic Tool for Threaded Inserts

74405 Series

Features

- Split tool
- Lightweight placing head
- Places threaded inserts up to M10
- Ideal for placing the Versa-Nut® threaded insert range up to M8

Benefits

- High placement speed
- Lightweight tool
- Robust tool
- Places a wide range of threaded inserts
- Ergonomic
- Ease of maintenance

Specifications

Head Weight (without nose equipment)	2.0 kg (4.4 lbs)
Pull Force @ 5.5 bar	13.84 kN (3111 lbf)
Stroke (maximum)	16 mm (0.63 in)
Air Supply Pressure	5 – 7 bar
Free air volume @ 5.5 bar	15 litres
Noise level	<75 dB(A)
Vibration	<2.5m/s ²

Placing capability

Avdel threaded inserts up to M10 including Versa-Nut® insert.



Dimensions (mm)

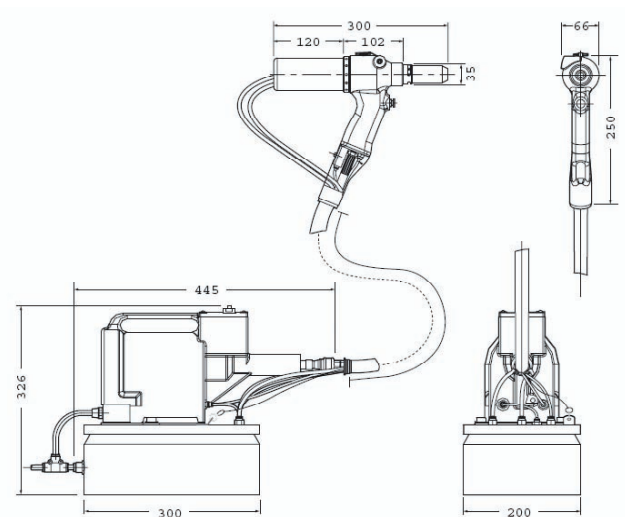

An Acument™ Global Technologies Company

Avdel USA LLC
614 NC Highway 200 South
Stanfield, North Carolina 28163
Tel. +1 704 888-7100 · Fax -0258
infoAvdel-USA@acument.com

www.avdel-global.com

Avdel Canada, a Division of
Acument Canada Limited
87 Disco Road
Rexdale, Ontario M9W 1M3
Tel. +1 416 67906-22 · Fax -78
infoAvdel-Canada@acument.com

© 2007 Acument Intellectual Properties, LLC

Versa-Nut® is a trademark of Acument Intellectual Properties, LLC

02.2007

Data shown is subject to change without prior notice as a result of continuous product development and improvement policy.
Your local Avdel representative is at your disposal should you need to confirm latest information.